

Heaty Racun 300 Advanced Plus

Water treatment for heating and cooling circuits for fixed installation



Insolent X

1	Introduction	6
1.1	The device	6
1.2	Conditions of use	6
1.3	Target group	7
1.4	Conventions	8
1.5	Manufacturer's address	9
2	Safety instructions	10
2.1	General information	10
2.2	Intended use	10
2.3	Non-intended use	12
2.4	Hazards during transport and installation	12
2.4.1	Transport and installation	12
2.4.2	Installation	12
2.5	Hazards during operation and maintenance	13
2.5.1	Mechanical hazards	13
2.5.2	Hazards due to hot surfaces	14
2.5.3	Hazards due to electric current	14
2.5.4	Dangers when handling the circulation pump	15
2.5.5	Hazards due to operating fluids	15
2.6	Personal protective equipment	16
2.7	Warning and information signs	16
3	Device description	17
3.1	Overview of the device	18
3.2	Circulating water inlet	20
3.3	Differential pressure detection	20
3.4	MAGella twister	20
3.5	Circulation pump	20
3.6	Circulating water output	20
3.7	Touch display	20
3.8	Cartridge	22
3.9	Dual filter	22
3.10	Changeover valve	23
3.11	Adjustable volume flow meter	23

3.12	Outlet filter cartridge	25
3.13	Solenoid valve	25
3.14	Filling/replenishment connection	25
4	Transport, installation and commissioning	26
4.1	Transport, installation	26
4.2	Installation and commissioning	26
5	Operation	30
5.1	Make settings in the control unit	30
5.1.1	Starting the system	30
5.1.2	Filling the system	31
5.1.3	Settings	32
5.1.4	Configuration	33
5.2	Operate appliance	41
5.3	Switch off device in an emergency	44
5.4	Switch off device	44
6	Maintenance and servicing	45
6.1	Maintenance schedule	45
6.2	Maintenance work	47
6.2.1	Change mixed bed resin	47
6.2.2	Clean MAGella twister	49
6.2.3	Change dual filter	49
6.3	Regular internal inspection	50
6.4	Spare parts and accessories	50
7	Dismantling and disposal	51
7.1	Specialised personnel	51
7.2	Dismantling	52
7.3	Disposal	52
8	Technical data	53
8.1	General data	53
8.2	Components	54
8.2.1	MAGella twister	54
8.2.2	Circulation pump	54

9	Other applicable documents	55
9.1	Measured values and conversion tables	55
9.1.1	Corrosion rate	55
9.1.2	Lime content and water hardness	56
9.2	MAGella twister10	58
9.2.1	Drawings	58
9.2.2	Characteristic curve	59
9.3	Quick guide changeover value	60
9.4	Modbus address tree	62
10	List of illustrations	64

1

Introduction

1.1 The device

The Heaty Racun 300 Advanced Plus treatment device for fixed installation is a device for initial filling with water and for the permanent treatment of water in heating systems and cooling systems using the bypass process (without inhibitors).

The device also fulfils the following tasks:

- Leakage monitoring
- Magnetic filtration
- Sludge or dual filtration
- Conductivity monitoring
- Pressure-controlled replenishment (optional)

Improper use of the appliance may result in personal injury and poor quality process results.

Please read these operating instructions carefully and take note of the safety, operating and maintenance instructions.

1.2 Conditions of use

To use the appliance properly, observe the following instructions:

- Before starting work, make sure that the heating or cooling system corresponds to the recognised state of the art.
- Observe the regulations on the construction, commissioning, design and filling of heating and cooling systems.
- When filling heating and cooling systems, operate the appliance with a flow pressure of at least 1.5 bar in the drinking water pipe.
- During water treatment or initial filling of a heating or cooling system without a bypass process, fully demineralised water (demineralised water) may cause existing deposits to be removed. Any resulting damage is due to the existing deposits.
- Ensure that there is an additional shut-off device at both the inlet and outlet of the circulating water.

- Always flush and clean heating and cooling systems in accordance with DIN EN 14336 if you are not using the appliance in bypass mode.
- The manufacturer does not guarantee compliance with the reference values if additives such as glycols, acids and cleaning agents or bacteria are present in the system
- If there is a risk of frost, completely drain the residual water from the appliance after work to protect it from damage.
- The installer is responsible for preparing and handing over the documentation in accordance with the relevant country-specific guidelines (e.g. VDI 2035, Ö-Norm H 5195-1 or SWKI BT 102-1). The operator is responsible for maintaining the documentation.

1.3 Target group

These operating instructions are intended for persons who work with or on the appliance:

- Operating personnel
- Maintenance and servicing personnel

Qualifications of the target group

The target group of the operating instructions must have at least the following qualifications:



- Operating personnel: **Instructed person**
An instructed person is a person who has been informed about the assigned tasks and the possible dangers of improper behaviour.
 - instructed,
 - trained if necessary and
 - has been instructed about the necessary safety equipment and protective measures.
- Maintenance and servicing personnel: **Specialist**
A specialist is a person who is able to assess the assigned work and recognise potential hazards based on their specialist training, knowledge and experience as well as knowledge of the relevant regulations.

1.4 Conventions

Warnings and other instructions

In the operating instructions, instructions are weighted differently and labelled with a pictogram.

Warnings are structured as follows:

Symbol	Signal word	Meaning
	DANGER	Warning notice: Immediate danger. Death or serious injury <u>will</u> result.
	WARNING	Warning notice: Potentially dangerous situation. Death or serious injury <u>may</u> result.
	CAUTION	Warning notice: Potentially dangerous situation. Slight or minor injuries <u>may</u> result.
	NOTE	Note: Information that must be observed to ensure optimum results and safe operation of the system.

- **Signal word**
Indicates the severity of the hazard.
- **Type and source of danger**
Indicates the danger being warned of and where it may occur.
- **Cause and effect**
Describes the cause of the hazard or damage and its effect.
- **Remedy**
Describes how the hazard can be prevented from occurring.

Example of a warning notice



DANGER

Risk of injury from improper use

Improper use of the Heaty Racun can result in danger to persons and property..

- Only use the device for its intended purpose as described below.
-

Handling instructions

Instructions are numbered consecutively to indicate the sequence of the individual steps. The results of the actions (if any) are shown directly below.

Example:

- 1 This is the first step.
- 2 This is the second step.
 - ▶ This is the result of the second step.

Operating and control elements

Operating elements, e.g. buttons and switches, as well as control elements, e.g. buttons on the control panel, are labelled in **bold**.

Example: The **emergency stop button** is located on the control panel.

1.5 Manufacturer address

UWS Technologie GmbH

Sudetenstraße 6
91610 Insingen
GERMANY

Internet : www.uws-technologie.de

E-mail : info@uws-technologie.de

Phone : +49 9869 91910-0

Fax : +49 9869 91910-99

2

Safety instructions

The Heaty Racun 300 Advanced Plus appliance has been designed and manufactured in compliance with applicable legal regulations and in accordance with recognised safety standards. The appliance corresponds to the state of the art at the time of its initial commissioning.

Nevertheless, hazards may arise for the operator, for other persons, for the appliance itself and for other material assets.



NOTE

To ensure safe handling of the appliance, observe the safety instructions in this section and the warnings in other sections of these operating instructions.

2.1 General information

The appliance may only be installed, operated and maintained by specialised personnel trained in safety technology.

Persons involved in the commissioning, operation, maintenance, repair, dismantling and disposal of the appliance must have read and understood the operating instructions and in particular the safety instructions.

The operating instructions must be kept in a safe place and be available at all times to persons working with or on the appliance.

2.2 Intended use

In order to use the appliance as intended, it is necessary to be familiar with the operating instructions and to comply with all instructions, maintenance and inspection regulations contained therein.



DANGER

Danger to life or risk of serious injury

There are mechanical and electrical hazards when operating the appliance. To prevent personal injury due to these hazards, only use the appliance as intended.

The device may only be used as intended as follows:

For the initial filling of heating systems and cooling systems (without inhibitors) with water and for the permanent treatment of water in heating systems and cooling systems (without inhibitors) using the bypass method. The following additional specifications apply:

- **Heating and cooling systems**

The device is intended for heating and cooling systems (without inhibitors) in larger residential and industrial buildings. Various device types are available, which must be selected depending on the size of the system (see section „8 Technical data“ on page 53).

- **Other tasks**

In addition to initial filling and treatment, the device fulfils the following additional tasks:

- Leakage monitoring
- Magnetic filtering
- Sludge or dual filtering
- Conductivity monitoring
- Pressure-controlled replenishment (optional)

- **Filling**

The device may only be filled with Vadion pH-Control mixed bed resin.

- **Operation**

The device may only be operated and maintained by persons who are sufficiently qualified and authorised.

- **Safety equipment**

The appliance may only be operated with intact safety devices. Safety devices must be checked regularly to ensure that they are in good condition and functioning correctly.

- **Maintenance and servicing**

General inspection and cleaning work must be carried out by trained personnel. Maintenance, servicing and repair work must only be carried out by qualified specialists.

2.3 Non-intended use

The appliance may only be used in the ways described in section „2.2 Intended use“ on page 10. Any other use may endanger persons and property and is prohibited. Non-intended uses include, but are not limited to

- Use for purposes other than the initial filling of heating systems and cooling systems (without inhibitors) with water and the treatment of water in heating systems and cooling systems (without inhibitors)
- Use in potentially explosive atmospheres as defined by the ATEX Directive
- Operation with defective or missing safety devices
- Maintenance and servicing in the absence of safety devices without increased safety measures
- Operation by unqualified or insufficiently qualified personnel

2.4 Hazards during transport and installation

2.4.1 Transport

During transport and installation of the appliance, hazards can arise due to heavy and tipping parts. To avoid this, observe the following safety instructions:

- Transport the appliance without impact or shock.
- Use suitable means to secure the appliance against tipping and falling over during transport. Only remove any transport locks once the appliance has been set up.

2.4.2 Installation

The appliance may only be installed by authorised and trained specialists. Improper installation can result in personal injury. To avoid this, observe the following safety instructions:

- Wear suitable personal protective equipment during work (see section „2.6 Personal protective equipment“ on page 16).

- Do not place any heavy objects on the appliance.
- Place the appliance on a level surface with sufficient load-bearing capacity.
- When connecting the appliance to the mains, ensure that the mains voltage corresponds to the specifications on the rating plate.
- Have the mains connection and earthing of the appliance carried out by qualified personnel in accordance with national regulations.
- Use an all-pole switch with a gap of at least 3 mm between the contacts to connect the appliance to the power supply.
- Install a high-sensitivity differential switch (0.03 A) as additional protection against electric shock.
- Lay cables and hoses in such a way that there is no risk of tripping.
- If tripping hazards cannot be avoided, mark the tripping hazards clearly.
- Carry out adjustments or simple repairs in consultation with the manufacturer.
- Do not make any changes to the appliance or to the water and power lines.
- Position the appliance so that the motor of the circulation pump is sufficiently ventilated.

2.5 Hazards during operation and maintenance

2.5.1 Mechanical hazards

The appliance consists of moving or heavy components. This can result in personal injury. To avoid this, observe the following safety instructions:

- Proceed with caution when replacing heavy parts:
 - Wear suitable safety shoes.
 - Secure the appliance against tipping and slipping.
- Observe the relevant manufacturer's documentation when carrying out maintenance work on supplied components.
- Do not reach into rotating or moving parts of the appliance while it is in operation.

2.5.2 Hazards due to hot surfaces

Parts of the appliance heat up during operation. There is a risk of burns from direct contact with hot surfaces. To avoid this, observe the following safety instructions:

- Do not touch hot pipes and the housing of the circulation pump when the appliance is switched on, but only after it has been switched-off and cooled down.
- Wear suitable protective gloves if you have to touch hot parts or work on hot parts.

2.5.3 Hazards due to electric current

The appliance is powered by electricity. Touching live components can result in dangerous injuries or death. To avoid this, observe the following safety instructions:

Disconnect the main power supply before working on electrical equipment

- Disconnect the plug from the main power supply before working on electrical equipment.
- Ensure that the mains cable is fitted with an appropriate locking device for maintenance protection (lockout tagout).

Liquids

- Be careful when handling liquids. Penetrating liquids can cause short circuits or electric shocks.

Connection data

- Observe the specified electrical connection data (see section „8 Technical data“ on page 53).

Covers of the electrical components

- Do not open the covers while the appliance is switched on or in operation.
- Do not remove covers even when the appliance is switched off if wiring work or inspections are being carried out.

2.5.4 Dangers when handling the circulation pump

The appliance uses a circulation pump, which poses various hazards. To avoid property damage and injury, observe the following safety instructions:

- Only use the appliance in accordance with the technical data (see section „8 Technical data“ on page 53).
- Do not use the appliance to transport highly flammable or hazardous liquids.
- Do not leave the appliance unattended during operation or ensure that unauthorised persons do not have access to the appliance.
- Switch off the appliance before carrying out maintenance and repair work and disconnect the mains plug from the socket.
- Do not operate the appliance with closed ball valves at the inlet and outlet of the appliance or the composite container.
- Check the area around the device for leakage and remove any escaping liquids.
- Protect the pump from environmental influences such as splash water or dust.

2.5.5 Dangers due to operating fluids

The device contains a mixed bed resin that must be replaced regularly. Skin or eye contact may cause irritation or even visual impairment. To avoid this, observe the following safety instructions:

- Observe the information in the safety data sheet.
- Wear suitable personal protective equipment when working to avoid skin and eye contact with the mixed bed resin:
 - Safety goggles
 - Protective gloves

2.6 Personal protective equipment

To work safely with the appliance, you must wear various items of personal protective equipment. In the following list and at the appropriate places in the document, you will find information on the required personal protective equipment.

The following personal protective equipment is required when working with the appliance:

- Protective gloves
- Safety goggles
- Protective work shoes







2.7 Warn- und Hinweisschilder

2.7 Warning and information signs

Places where there is a potential hazard under certain conditions are labelled with warning and information signs

- Do not remove warning and instruction signs.
- Replace damaged or removed warning and information signs immediately.

The following warning and information signs are located on the appliance:

Sign	Meaning	Sign	Meaning
	Warning of electrical voltage		Warning of magnetic field
	Warning of hot surface		No access for persons with pacemakers or implanted defibrillators

3

Device description

The Heaty Racun 300 Advanced Plus filling device is a device for the initial filling of heating systems and cooling systems (without inhibitors) with water and for the permanent treatment of water in heating systems and cooling systems (without inhibitors) using the bypass method.

The device also fulfils the following tasks:

- Leakage monitoring
- Magnetic filtration
- Sludge or dual filtration
- Monitoring of conductivity and pressure conditions
- Pressure-controlled replenishment (optional)

The device is intended for permanent connection to a heating or cooling system and switches off automatically when treatment is complete or the set conductivity has been reached.

The device is intended for use in heating or cooling systems in larger residential and industrial buildings.

The following section describes the appliance, its components and operating elements.

3.1 Overview of the device

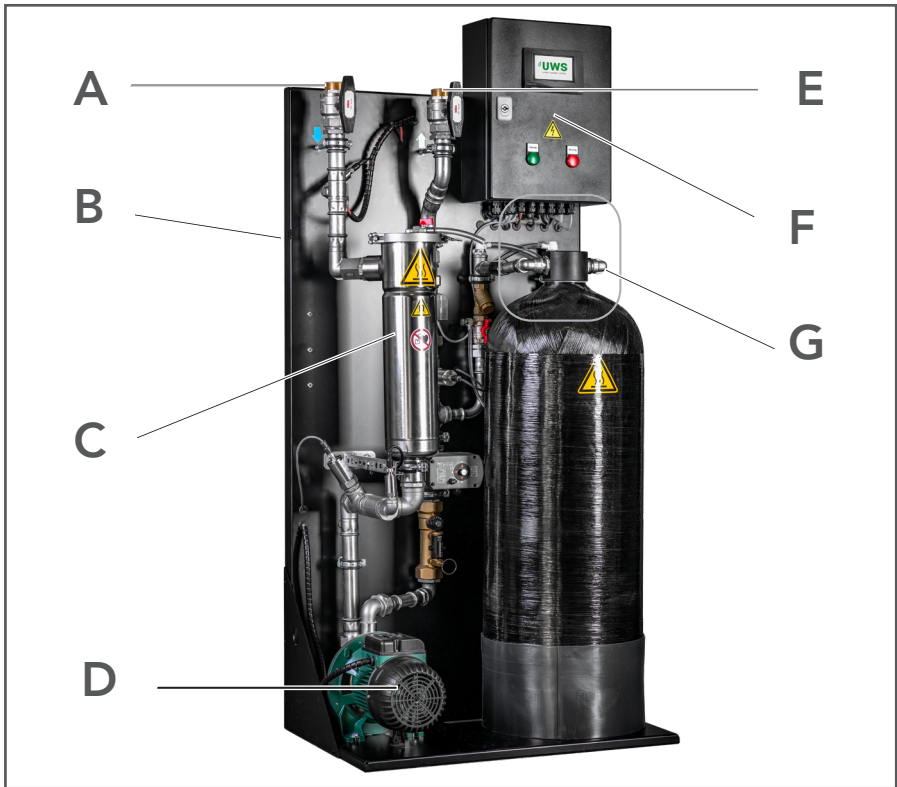

Fig. 3-1: Overview of the device components

- A Circulating water input
- B Mains cable
- C Dual filter MAGella twister10
- D Circulation pump
- E Circulating water output
- F Control unit with touch display
- G Cartridge connection

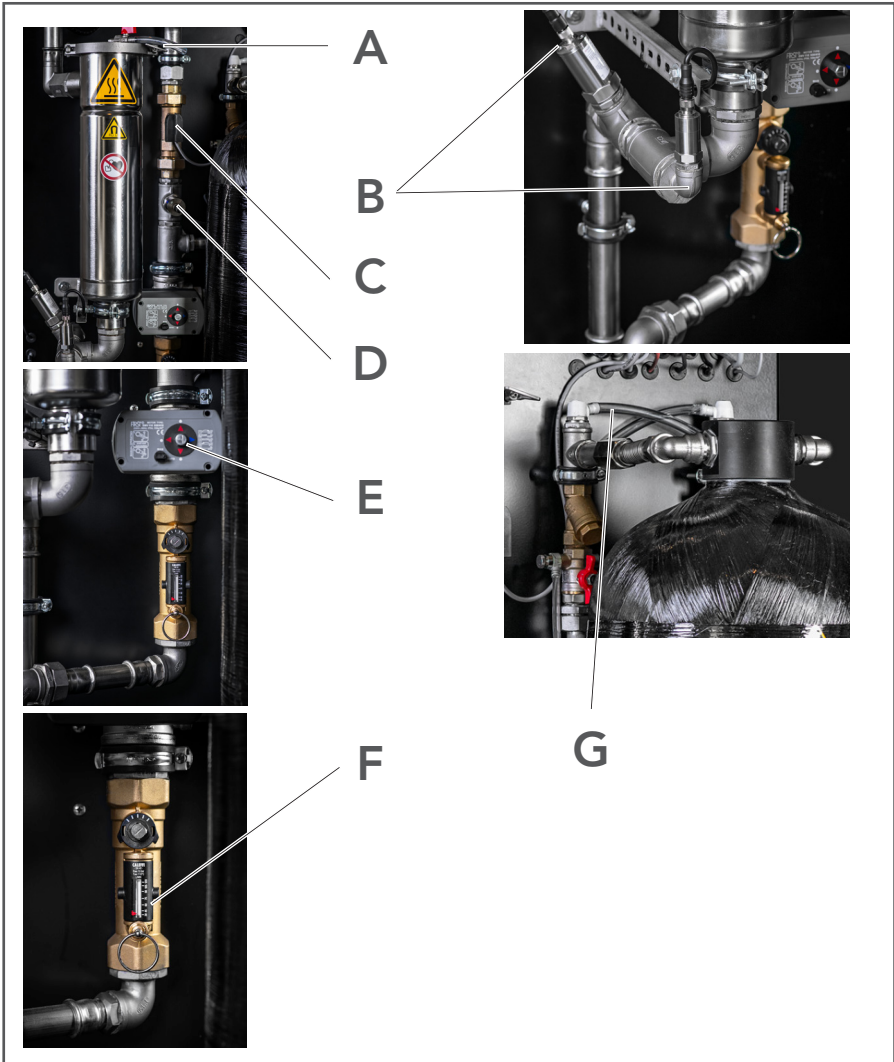

Fig. 3-2: Detailed views

- A Filter deaeration
- B LF 1 and pressure sensor
- C Flowmeter
- D LF 2 after cartridge

- E Changeover valve
- F Adjustable volumetric flow meter
- G Cartridge connection with vents and relief

3.2 Circulating water input

The return of the heating or cooling system is connected to the circulating water inlet. The circulating water of the system, whether heating or cooling system, is conveyed through the device and mixed back into a remote return.

3.3 Differential pressure measurement

The differential pressure measurement device is used to measure the contamination level of the dual filter. It switches off at a differential pressure of 1.75 bar to protect the dual filter.

3.4 Dual filter (magnetite and fine filter)

The MAGella twister10 dual filter is a unique, highly efficient system filter for magnetic and non-magnetic impurities in heating systems. It contains an absolute fine filter up to 1 µm and a magnetraw with 11 x 12,000 gauss. Further information on the MAGella twister10 can be found on page 49 and page 54.

3.5 Circulation pump

The circulation pump pumps the water through the appliance.

3.6 Circulating water output

The return flow from the heating or cooling system is connected to the circulating water outlet. The output circulating water transports the treated water from the appliance into the heating or cooling system circuit.

3.7 Touch display

You can use the touch display to access the appliance controls. Settings can be made and functions activated or deactivated in the touch display menus. Further information can be found in section „5.1 Making settings in the control unit“ on page 30.

The display has the following control elements:

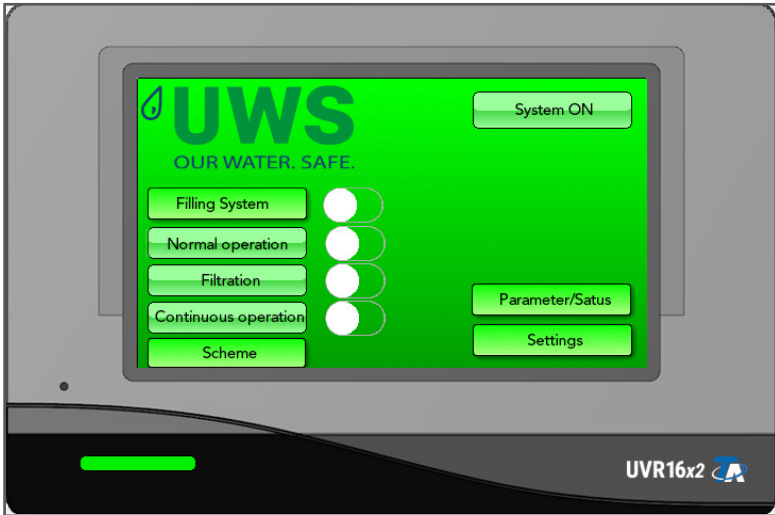

Figure 3-3: Components of the touch display
Information on the individual functions and settings can be found in section „5.1 Making settings in the control unit“ on page 30.

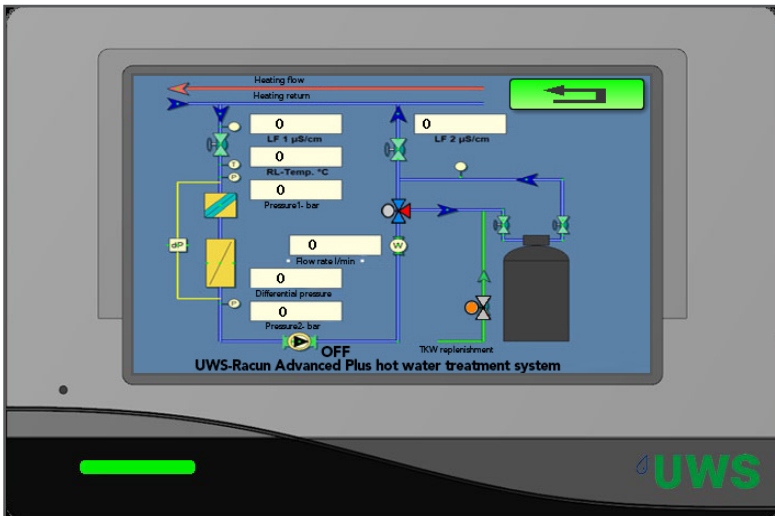

Fig. 3-4: Components of the touch display

3.8 Cartridge

Water treatment takes place in the mixed bed resin of the cartridge by ion exchange until the capacity of the mixed bed resin is exhausted. The cartridge can be rinsed automatically at regular intervals to prevent the cartridge from becoming contaminated (see ‚Cartridge protection‘ function in section ‚5.1.3 Settings‘ on page 32).

3.9 Dual filter

The dual filter of the MAGella twister series is a unique, highly efficient system filter for magnetic and non-magnetic impurities in heating systems. It includes an absolute dual filter up to 1 μ and one of the most powerful magnetite filters on the market.

The dual filter with pressure spring removes even the finest dirt particles from the heat system. With a flow rate of 5 or 10 m³/h, it is also ideal for use in very large heat systems. The twister insert permanently distributes the volume flow and provides a retaining barrier for heavy magnetite particles. The stainless steel housing provides additional shielding against the high magnetic flux strength.

The dual filter is designed as follows:



Fig. 3-7: The dual filter in the disassembled state

- | | | | |
|---|-------------------------|---|---------------|
| A | Clamping ring | D | Filter basket |
| B | Stainless steel housing | E | Magnetic rod |
| C | Filter bag | | |

3.10 Changeover value

The changeover value is an electromotor-driven ball valve that switches the internal bypass depending on the conductivity. If the LF1 measuring probe detects a deviation from the set conductivity, the water is channelled through the cartridge. When the set conductivity is reached, the changeover value switches and the water only flows through the magnetic flux filter.

3.11 Adjustable volumetric flow meter

The adjustable flow meter is a fitting for precisely adjusting the flow rate of a heating or cooling system. The regulation of the hydraulic lines ensures that the heating or cooling system functions perfectly.

The volumetric flow meter is equipped with a flowmeter for direct measurement and reading of the set flow rate. The flowmeter is installed in the bypass and can be switched off during operation. It is located on the housing of the volumetric flow meter and enables regulation without the aid of manometers and diagrams.

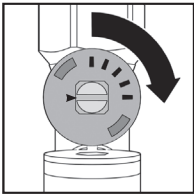

Close

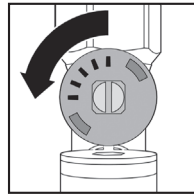

Open

Zur Regulierung der Durchflussmenge wie folgt vorgehen:

1. Use the display (1) to pre-set the reference flow rate to which the valve is to be set.
2. Use the ring (2) to open the gate valve, which under normal conditions prevents the medium from flowing through the flowmeter (3).

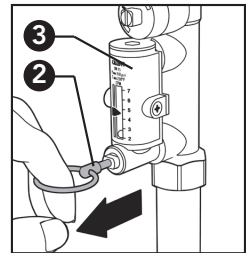
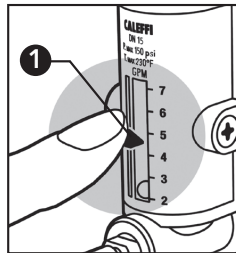

3. Hold the slide open and make the setting on the valve control spindle (4) with a 9 mm spanner for sizes from 1/2" to 1 1/4" or with a 12 mm spanner for sizes from 1 1/2" to 2". The set flow rate is indicated by the metal ball (5) in a transparent guide (6), next to which there is a scale on which the value can be read in litres per minute.

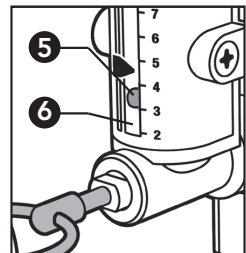
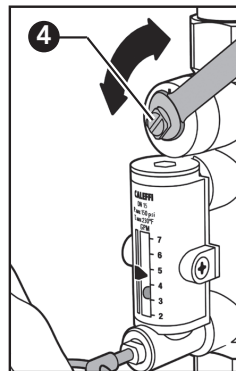

4. After adjustment, release the ring (2) of the flowmeter slider; a built-spring causes it to automatically return to the closed position.
5. The display (1) can be used to memorise the setting made for later checks.

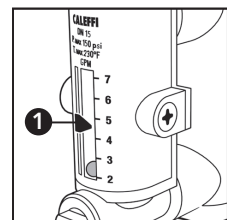
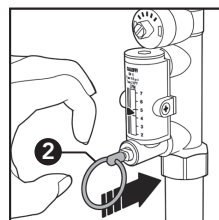

i n
t i -
l a -

Safety instructions

If the adjustable flowmeters with built-in flowmeter are not correctly installed, commissioned and maintained as described in these instructions, they may not function correctly and pose a risk to the user.

Remove any deposits, rust, incrustations, welding residues and other impurities from the lines.

As in any hydraulic circuit, particular attention must be paid to cleaning the entire system. Check the tightness of all connection fittings. For optimum operation, the air contained in the medium must be drained.

Due to the high compressibility of air, we do not recommend leak tests with compressed air on the entire system and especially on the valves for safety reasons.

When designing the hydraulic connections, care must be taken to ensure that the thread of the valve housing is not mechanically overstressed.

Over time, damage can occur with leakage losses and resulting damage to property and/or personal injury.

Water temperatures above 50°C can lead to severe scalding. During installation, commissioning and maintenance of the valve, the necessary precautions must be taken to ensure that these temperatures cannot endanger persons.

Use for purposes other than those for which it is intended is prohibited.

3.12 Cartridge outlet filter

The cartridge outlet filter is used to prevent damage to the suction lance and head nozzle in the cartridge to prevent resin from escaping.

3.13 Solenoid valve

The solenoid valve is closed when de-energised and switches off the drinking water supply during pressure-controlled replenishment if the set limit value for maximum replenishment is exceeded.

3.14 Filling/backfeed connection

The drinking water pipe is connected to the filling/backfeed connection in order to fill a heating or cooling system.

4

Transport, installation and commissioning

4.1 Transport

Use lifting equipment such as a crane or forklift truck to transport the appliance. The lifting equipment must be suitable, tested and authorised.

Observe the following instructions during transport:

- Use suitable aids to secure the appliance against slipping and tipping over.
- Only load the appliance at suitable points during transport.
- Remove the transport devices after transport.

4.2 Installation and commissioning

To prevent damage to the appliance or injury to persons, observe the following instructions during installation and commissioning:

- Installation and commissioning may only be carried out by trained specialists from a recognised specialist company in the HVAC sector, taking into account the necessary safety measures.
- Before starting installation, check the appliance for completeness and any transport damage. The following components are included in the scope of delivery:
 - Device as ordered, pre-assembled
 - Operating instructions
 - Maintenance key Dual filter MAGella twister
- Place the appliance on a firm and level surface.
- Do not install the appliance in areas at risk of frost.
- When choosing the installation location, ensure that there is sufficient space to carry out maintenance work (e.g. changing the mixed bed resin, cleaning the dual filter).
- Lay cables and pipelines in such a way that there is no risk of tripping. Mark unavoidable tripping hazards.
- Connect the appliance to the power supply correctly and observe the electrical connection data (see section „8 Technical data“ on page 53).

- If a connection to the building management system is planned, this work must be carried out by a qualified electrician. Observe the terminal diagram (see section „9.4 Terminal diagram for control system“ from page 62).

The device is intended for fixed installation in a heating or cooling system. Observe the following instructions during installation:



Familiarise yourself with the specific structure of the heating or cooling system before installing the device. For proper integration, contact the manufacturer. The integration is determined on the basis of a schematic drawing.

- Select the points for integrating the device into the return of the heating or cooling system so that they are far enough apart. A short circuit must be avoided. Please observe the direction of flow so that the treated water cannot enter the measuring range.
- Install an 1½" connection piece with a shut-off valve at each point in the return flow of the heating or cooling system.
- Lay pipelines from the connection pieces to the circulating water inlet and to the circulating water outlet of the device:



- Connect the filling/replenishment connection to the drinking water pipe. Use the screen seal supplied to prevent malfunctions of the changeover valve:

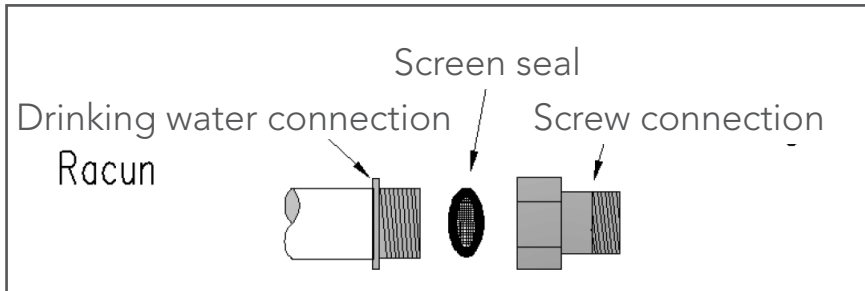

- When connecting to the drinking water pipe, use a filling combination from the manufacturer (see section „6.4 Spare parts and accessories“ on page 50).
- The drinking water must not exceed a temperature of 25° C and must be free of suspended matter. Connect an appropriate filter system upstream if necessary.
- The drinking water pipe must have a flow pressure of at least 1.5 bar when filling heating or cooling systems. The filling combination causes a pressure loss of approx. 1 bar. Use a suitable pressure booster system if the system pressure must be higher than the flow pressure of the drinking water pipe.
- Ensure that the installation work is carried out professionally and that the result complies with the relevant regulations and provisions.

The following figure shows an example of connecting the device using the bypass method:

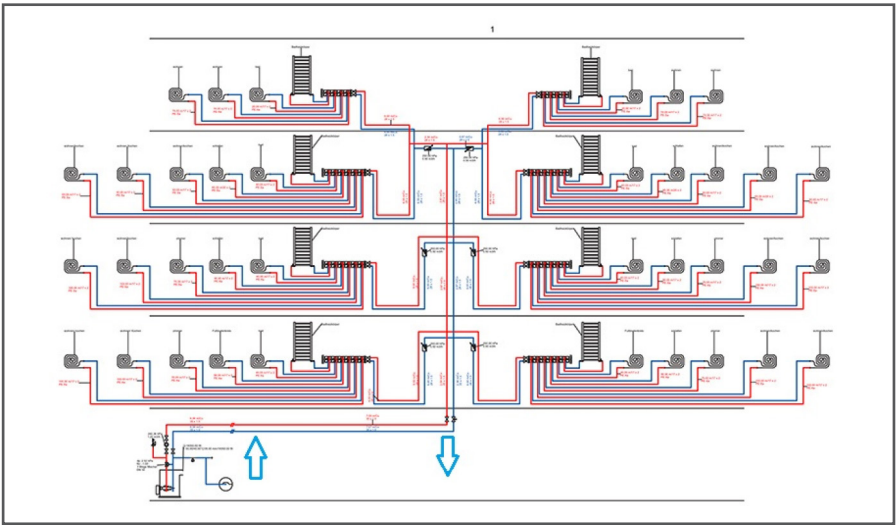

Figure 4-8: Connection diagram bypass method

5 Operation

The following section contains information on operating the appliance.



NOTE

Control elements

The control elements referred to in the text are explained in section „3 Device description“ on page 17.

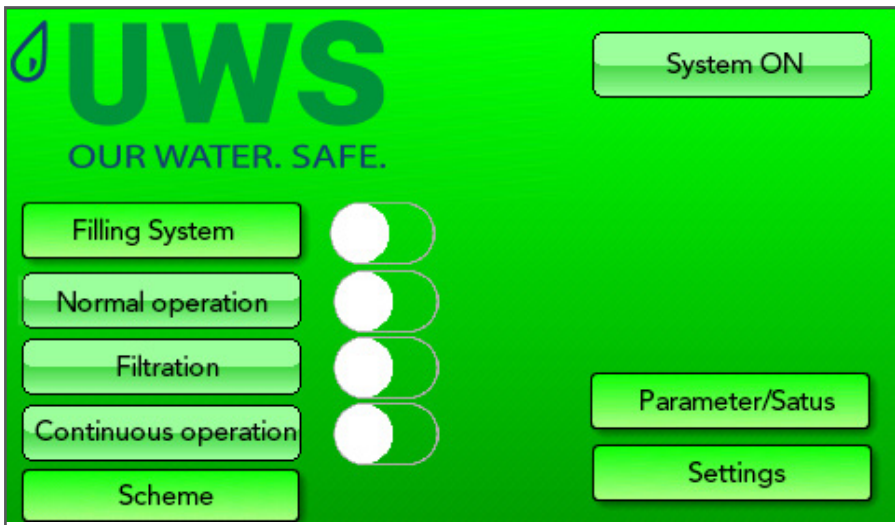

5.1 Making settings in the control unit

The touch display (see „3.7 Touch display“ on page 20) gives you access to the appliance controls. You can make the following settings and activate or deactivate functions in the control unit menu:

5.1.1 Starting the system

The **System ON** function starts or stops the appliance regardless of the operating mode.

5.1.2 Filling the system

The **Fill system** function is used to define which of the two filling parameters leads to the automatic switch-off of the appliance when reached. The following filling parameters are available for selection:

- Volume of the heating or cooling system (filling quantity in litres)
- Target pressure, filling quantity and duration of filling (time in minutes)

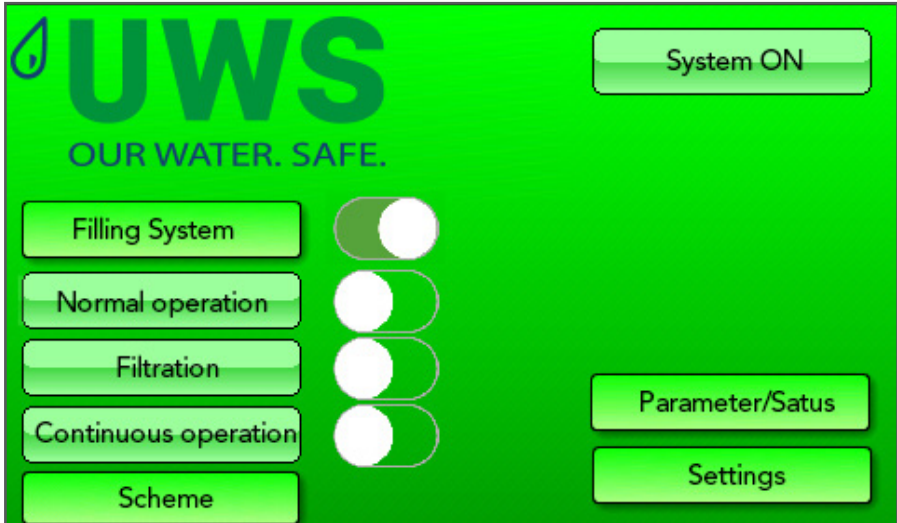

5.1.3 Settings

Measurement delay

The measurement delay function is used to set the measurement delay for long connection lines between the device and the heating or cooling system. With this function, water quantities in a long line are taken into account by the device.

Limit value LF1

The limit value LF1 function is used to specify the limit value for the conductivity in the range of 30-500 μS .

Desalination hysteresis

The hysteresis desalination function is used to set the tolerance for the limit value LF1 in the range of 1-95 μS in order to prevent constant starting and stopping of the treatment.

Example: With a set limit value LF1 of 100 μS and a hysteresis of 20 μS , the treatment is only reactivated from a conductivity of 120 μS or deactivated from 80 μS .

Desalination delay

The desalination delay depends on the size of the cartridge and is preset by the manufacturer

Temperature limit value

The Temperature limit function is used to specify a limit value for the water temperature (max. 80°C) at which the appliance is switched-off.

Maximum conductivity from cartridge

The Maximum conductivity from cartridge function can be used to set a limit value for the consumption of the cartridge and thus control the treatment. Recommendation: Factory setting of 60 μS .

Maximum replenishment

The Maximum backfeed function is used to specify a limit value for replenishment in litres/week. Exceeding this limit value can indicate a pipe break, leakage or similar and leads to the make-up being shut off by the solenoid valve. Exceeding the limit value is signalled by an alarm on the flow diagram with status display (see section „3.7 Touch display“ on page 20) and, if necessary, transmitted to the building management system.

Cartridge protection

The cartridge protection function is used to activate or deactivate the automatic flushing of the cartridge and to set the interval for automatic flushing (1-30 days).

5.1.4 Configuration

Operating mode

The operating mode function can be used to select between the operating modes continuous operation, normal operation and filtration.

Differential pressure

The differential pressure function is used to display the differential pressure for the degree of soiling of the dual filter.

Reset water meter

The Reset water meter function is used to reset the internal water meter in order to start a new measurement.

Delete leakage times

The Reset leakage times function is used to reset the counter for the maximum make-up water supply in order to start a new measurement.

Factory settings

The basic settings are made during commissioning. These are retained until a change is made.

Language

Only German is currently available.

Interface communication

Fault messages can be forwarded via a potential-free contact. Connection via Modbus is optional.

Actual status parameters

The actual status can be queried at any time by scrolling through the screen. The cartridge protection can also be reset in this program step.

Fault display

If set values are outside the tolerances, a fault display appears on the screen and indicates the respective fault.

Set password

Service password: available on request.

Settings: the last 4 digits of the serial number (on label)) - without spaces.

5.1.3 Settings and 5.1.4 Configuration

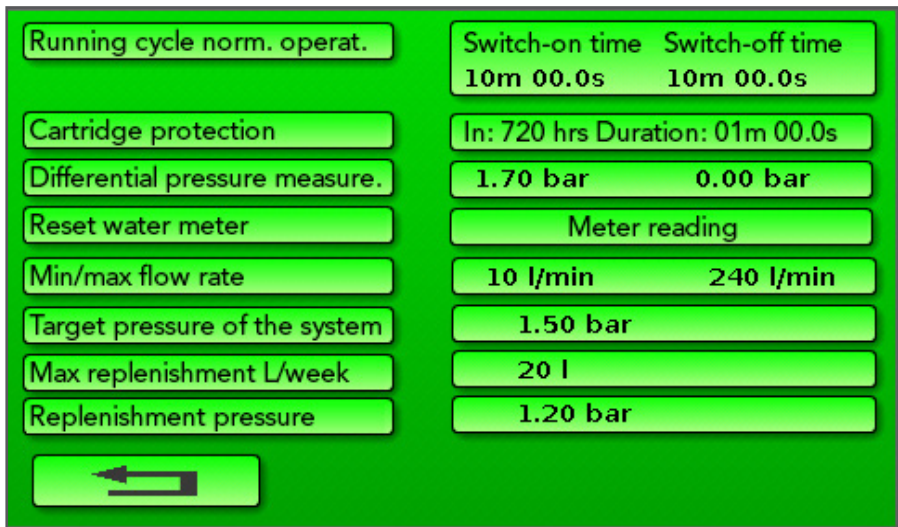
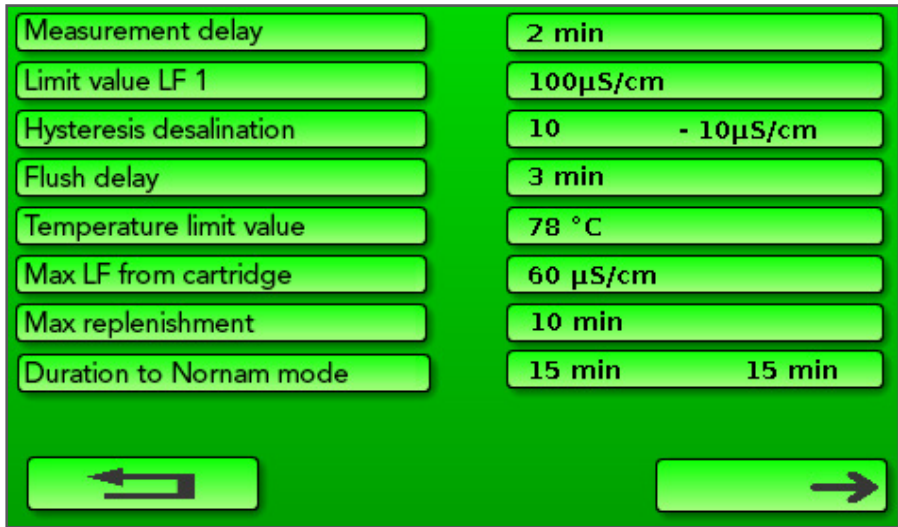

The parameters described in 5.1.3 Settings are shown on 6 display screens. Use the button to scroll through the pages.

Self-explanatory controller displays



Operating modes:



Continuous operation with conditioning

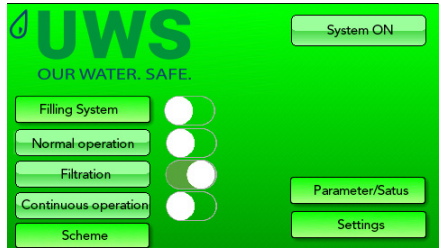

Filtration without treatment



Normal operation as described



Fill the system as described

Self-explanatory controller displays - Actual state parameters

Pressure sensor 1	0 bar
Pressure sensor 2	0 bar
Flow sensor	0 l/min
Conductivity sensor 1	0 µS/cm
Conductivity sensor 2	0 µS/cm
Normal operation	Standby in : 0 min
Cartridge protection	In: 0 min 0 min
Measurement delay	0 min
Flush delay	0 min
Resin changed	Reset

Self-explanatory controller displays - Fault menu

- Interferences
- Flow rate exceeded
- Flow rate undershot
- Temperature too high
- Filter dirty
- Replenishment fault
- Max replenishment reached
- Pressure P1 exceeded
- Pressure P1 undershot

Self-explanatory controller displays - Fault message

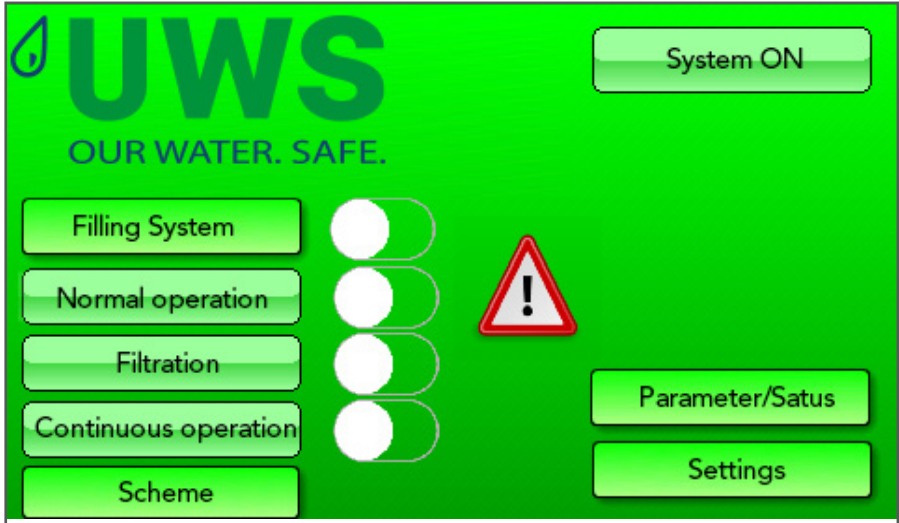

Self-explanatory controller displays - Exemplary fault message

By unlocking the fault message - after the fault has been rectified - the fault message disappears.

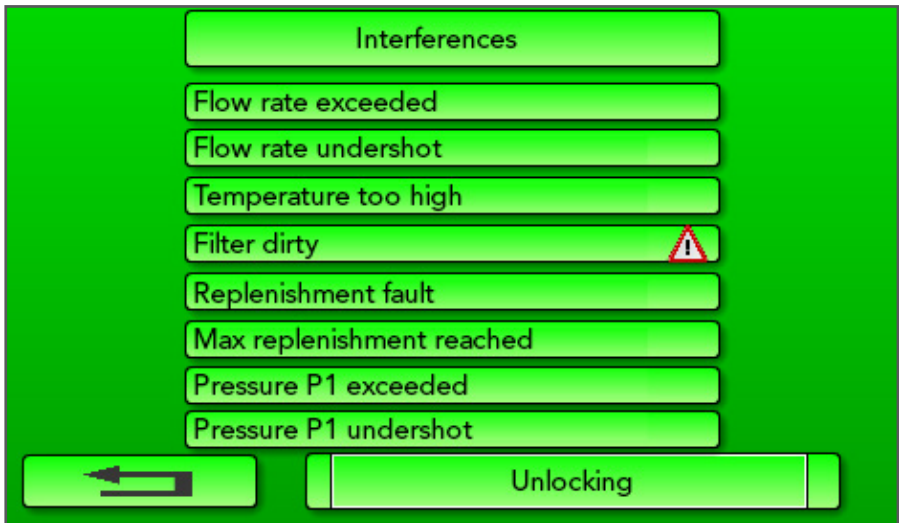

Self-explanatory controller displays

Pressing the Scheme button displays an overview screen with all the relevant information.

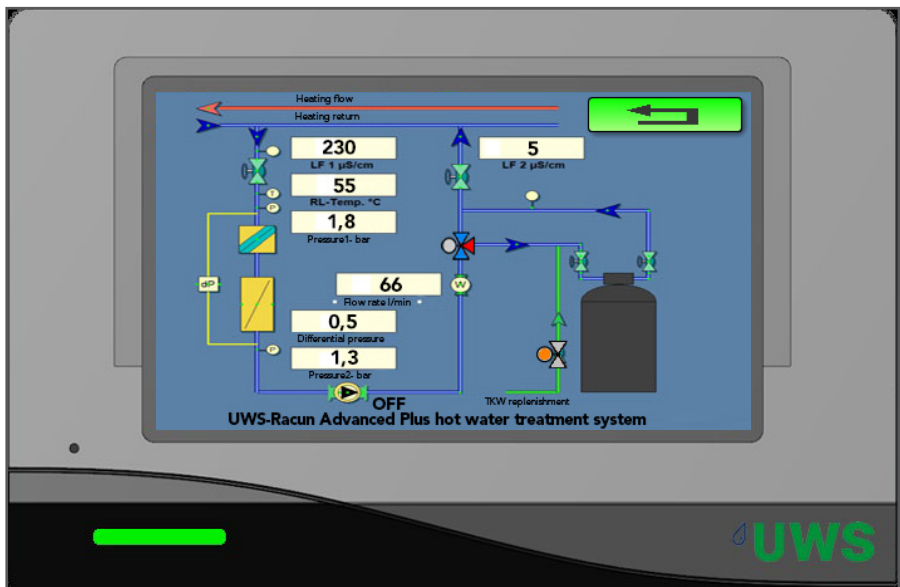
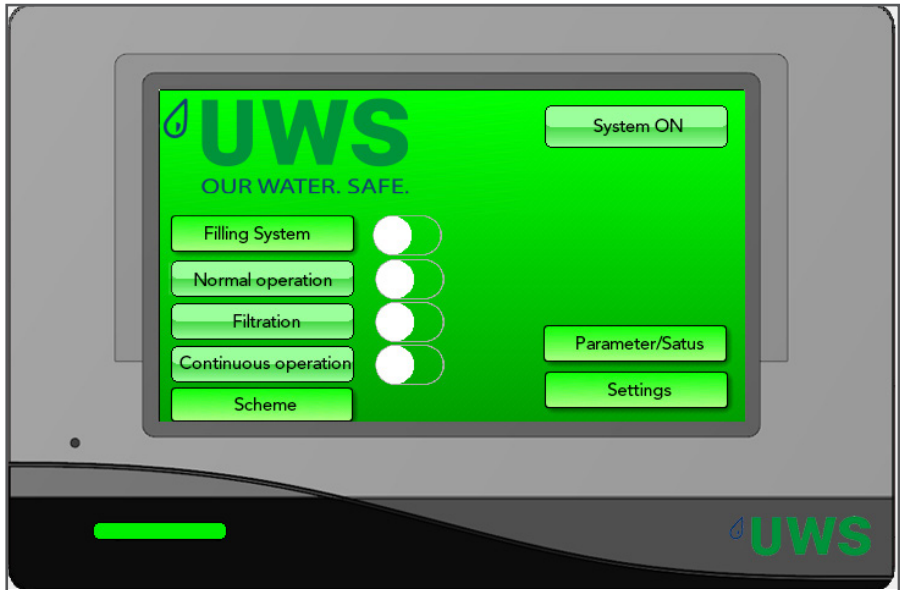



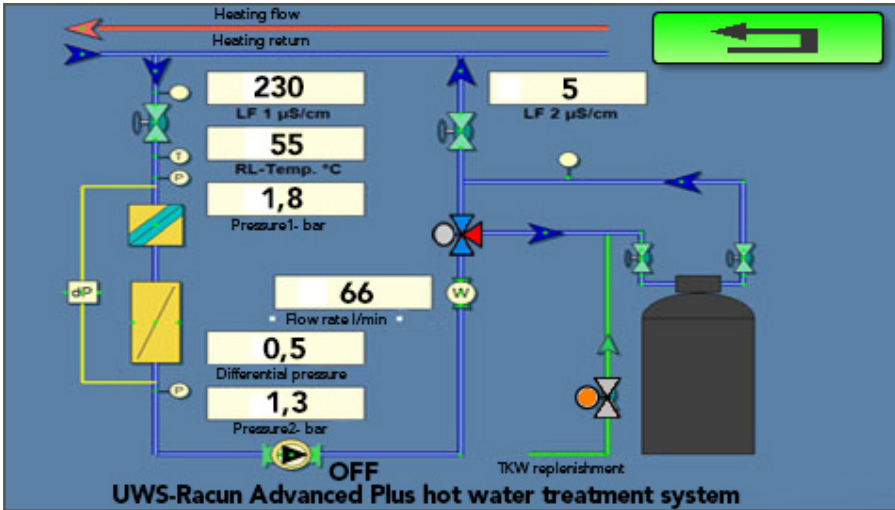

Self-explanatory controller displays

Pressing the Scheme button displays an overview screen with all the relevant information.



Description

The following values are displayed:

Conductivity 1	from the mains
Return temperature	from the mains
Inlet pressure - Pressure 1	from the mains
Circulation volume	the amount of water through the treatment device
Differential pressure	Pressure difference between inlet pressure and pressure after magnetic flux filter and dual filter (pressure 1 - pressure 2)
Pressure after filtration - pressure 2	Formation of differential pressure
Pump status	On - Off
Changeover value	Display for operation with / without treatment  
Conductivity 2	Conductivity a) after treatment by mixed bed b) without treatment by mixed bed after switchover
Replenishment	active  inactive 

Serial number

The serial number is located on the front of the device.



DANGER

Danger of electric shock

The control unit is live. Only open the control unit when it is de-energised.



NOTE

Pulling the mains plug

Disconnect the mains plug from the socket before carrying out any work on electrical components and in the switch cabinet.

5.2 Gerät betreiben



CAUTION

Ühecking the heating or cooling system before initial filling

Before filling a heating or cooling system with the appliance for the first time, observe the following instructions:

- Spülen und reinigen Sie die Heizungs- oder Kühlanlage gemäß EN Flush and clean the heating or cooling system in accordance with EN 14336 and record the flushing and cleaning.
- Measure the conductivity and water hardness of the untreated water and enter the values in the system log.
- If the raw water is softened, measure the conductivity and use the conversion tables to estimate the capacity of the appliance (see section „9 Other applicable documents“ on page 55).
- Please note that the use of a water softener can lead to increased conductivity of the drinking water.
- Ensure that the drinking water pipe has a flow pressure of at least 1.5 bar when filling heating or cooling systems. If the pressure falls below this value, the capacity of the appliance may be impaired.
- The drinking water must be free of suspended matter. If necessary, connect an appropriate filter system upstream.
- Observe the instructions for reducing conductivity during operation.
- Ensure that a filling combination is installed on the appliance before the filling/replenishment connection. Observe the regulations of the responsible water supply companies.
- The use of a filling combination can lead to a pressure loss of approx. 1 bar. Use a suitable pressure booster system if the system pressure must be higher than the flow pressure of the drinking water pipe.

To operate the device, proceed as follows:

Prerequisites

- The appliance has been professionally installed as described in section „4.2 Installation and commissioning“ on page 26.
- The MAGella twister dual filter has been checked and replaced or cleaned if necessary (see section „6 Maintenance and servicing“ on page 45).

Procedure

- 1 Open the drinking water pipe to which the **filling/replenishment** connection is connected.



NOTE

The volume flow through the appliance is limited by the integrated flow limiter. You can fully open the drinking water pipe.

- 2 Insert the mains plug into the socket.



NOTE

Observe the electrical connection data when connecting (see section „8 Technical data“ on page 53).

- 3 Use the touch display to make the desired settings on the control unit:
 - Select the operating mode (**continuous or normal operation - operating mode function**)
 - Set the filling parameters (**Fill system function**)
 - Specify the desired conductivity (**Limit value LF1 function**)Adjust other operating parameters if necessary.



NOTE

Selecting the operating mode

You can choose between the following operating modes under the Operating **mode** function:

- Normal operation: Treatment pauses when the set limit value is reached, after 2 hours of constant conductivity the device goes into standby mode
 - Continuous operation: Continuous treatment (suitable for heating or cooling systems heavily contaminated with magnetite or wet sludge)
 - Filtration: Pure filtration of magnetite and particles up to 1 µm
-

- 4 Ensure that the system temperature of the heating or cooling system is a maximum of 80 °C.
- 5 Ensure that the **circulation pump vent** is closed.
- 6 Open the fittings on the connections of the heating or cooling system.
 - ➔ A partial volume flow of the heating or cooling system flows through the appliance.
- 7 Use the **Start/Stop** function on the touch display to start the appliance.
 - ➔ The appliance begins treatment of the circulating water.

The circulating water flows through the device and is channelled through the cartridge as required. The following measurements are used for this purpose:

- Measuring probe LF1: Measurement of the conductivity before treatment in the bypass
- Measuring probe LF2: Measurement of the conductivity after the cartridge to monitor the capacity

Function of the device in normal operation

If the conductivity before treatment (measuring probe LF1) is too high, the changeover value switches to bypass to the cartridge. When the set conductivity limit value is reached, the changeover value switches to internal bypass. The water no longer flows through the cartridge. The conductivity is continuously measured by the measuring probe LF1. In the event of deviations, the changeover value switches back to flow to the cartridge until the set conductivity limit value is reached.

If the conductivity remains constant for a period of 2 hours, the device is switched to standby mode.

During standby mode, the device checks the conductivity daily at an adjustable wake-up time. If there are deviations, treatment is restarted.

In the case of pressure-controlled replenishment, the device records the backfeed water quantity and stops the replenishment when the maximum replenishment is reached.

5.3 Switching off the device in an emergency

To switch off the device in an emergency, proceed as follows:

- 1 Pull the mains plug out of the socket.
 - ▶ The device is switched off.
- 2 Eliminate all reasons that caused the appliance to switch off.

To switch the appliance back on after an emergency, proceed as described in section „5.2 Operating the appliance“ on page 41.

5.4 Switching the appliance off

To switch off the appliance after treatment is complete, proceed as follows:

- 1 Use the **Start/Stop** function of the touch display to stop the appliance.
- 2 Pull the mains plug out of the socket.
- 3 Allow the appliance to cool down.
- 4 Close the fittings on the heating or cooling system so that no more partial volume flow passes through the appliance.
 - ➔ The appliance is switched off.



Maintenance and servicing

To ensure trouble-free operation of the appliance, it must be kept in a clean and functional condition. Furthermore, regular visual and functional checks must be carried out in order to recognise and rectify any damage at an early stage.



WARNING

Risk of injury due to improperly performed maintenance work

The appliance may only be serviced by qualified personnel trained in safety technology.

Carry out the following steps before carrying out any maintenance and servicing work:

- Switch off the appliance.
 - Disconnect the appliance from the power supply.
 - Take suitable measures to prevent the appliance from being switched on again.
 - Also observe the safety instructions in section „2 Safety instructions“ on page 10.
-

6.1 Maintenance schedule



NOTE

Different intervals in continuous operation

If the appliance is operated continuously, shorter maintenance intervals may be necessary. Coordinate the intervals with a specialist, taking into account the operating conditions.

The following table contains an overview of the maintenance work to be carried out regularly:

Interval	Activity	Responsibility
Before installation in a heating or cooling system	Check the dual filter and change the fine filter depending on the contamination level	Operating personnel
	Check suction lance nozzles for damage and blockages and clean or replace if necessary	Operating personnel
	Check the flow limiter for blockages	Operating personnel
Monthly	Check pipelines for leakage and replace if necessary	Operating personnel
Half-yearly	Check the attachment and position of the appliance as well as welded and screw connections	Operating personnel
Annually	Check warning notices and labelling on the device	Operating personnel
	Clean measuring probes LF 1 and LF 2	Operating personnel

6.2 Maintenance work

6.2.1 Changing the mixed bed resin



NOTE

Carrying out the change

For the Heaty Racun 300 Advanced Plus appliance type, it is recommended that the mixed bed resin is changed by the manufacturer's service personnel. Cartridge hire from the manufacturer, including delivery and collection service, is available on request.



NOTE

Handling mixed bed resin

Observe the following points when handling the mixed bed resin:

- Do not store the mixed bed resin open, otherwise it will lose its capacity.
 - Please do not store at temperatures below 0 °C or above 50 °C!
 - Use the outer packaging of the refill pack to dispose of the replaced mixed bed resin.
 - Replace the mixed bed resin over a drain so that the water separated from the replaced mixed bed resin can drain away.
 - Wear suitable personal protective equipment (safety goggles, gloves).
-

Proceed as follows to change the mixed bed resin in the composite container when the LED indicator signals this:

- 1 Ensure that the appliance is **switched off** and **disconnected from the power supply**.
- 2 Close the **cartridge stopcock** on the left and right of the cartridge.
- 3 Open the **cartridge drain** on the left and right of the cartridge to vent the cartridge.
- 4 Open the **union nuts** and remove the cartridge.

5 Turn the head anti-clockwise to release the head.



6 Pull the head with the suction lance out of the cartridge.



- 7 Remove the refill pack of mixed bed resin from the outer packaging and place the outer packaging in a sufficiently large container.
- 8 Empty the exhausted mixed bed resin from the composite container into the container with the outer packaging:
 - ▶ The mixed bed resin is retained by the outer packaging and the water collects in the container.
- 9 Dispose of the mixed bed resin and empty the water into a drain.
- 10 Open the mixed bed resin refill pack and fill it into the cartridge using a funnel. If necessary, compact the mixed bed resin by shaking or circling the cartridge.

- 11 Fill the cartridge with water to a height of approx. 2 cm below the thread.
- 12 Stir the mixed bed resin with a pipe or other suitable tool to make it asier to insert the head with suction lance.
- 13 Insert the head with suction lance back into the cartridge.
- 14 Tighten the head clockwise by hand.
 - ➔ The mixed bed resin has been changed and the cartridge is working at full capacity again.

6.2.2 MAGella twister maintenance

Technical information on the MAGella twister can be found in section „9.2 MAGella twister“ on page 58.

6.2.3 Changing the dual filter and cleaning the magnetraw



NOTE

The dual filter must be checked and replaced if necessary before the appliance is installed in a heating or cooling system.
 The dual filter must be replaced at the latest after the treatment of 1,100 m³ of water.

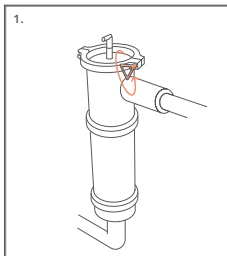

1. Close the inlet and outlet fitting. Open the KFE tap to release the pressure. Then open the bleed tap at the top of the filter. Unscrew the wing nut and remove the cap

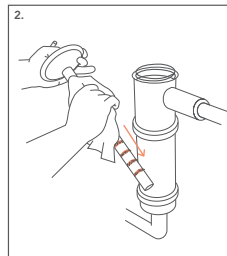

2. Remove the magnetic rod and clean it with a cloth, for example.

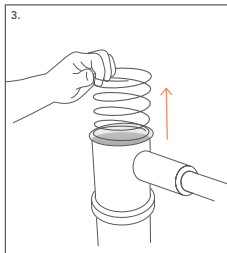

3. Then remove the pressure spring and clean it with water if necessary

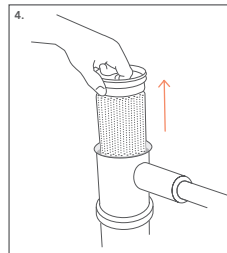

4. You can now remove and replace the basket with the dual filter bag (spare part number 100454)

Assembly is carried out in reverse order.

The twister insert on the magnetic rod should be directed towards the input to achieve the highest capacity.

6.3 Regular internal inspection

Certain parts of the appliance are additionally checked and serviced at regular intervals:

- Circulation pump
- Measuring probes LF 1 and LF 2
- Outlet filter cartridge
- Flowmeter
- Pressure sensors for differential pressure measurement of the filtrations

The test dates must be coordinated by the operator.



NOTE

Service from the manufacturer

to the appliance and must not be replaced by the customer. The manufacturer's customer service department must be contacted in the event of faults or malfunctions.

6.4 Spare parts and accessories

The following spare parts and accessories are available for the device from the manufacturer:

Art. No.	Designation
100041	Funnel
100047-1	„PROFI“ measuring case
100055	Refill pack 23 l mixed bed resin (Vadion pH Control, 3 pieces required for complete refill)
300900	UWS filling combination 1/2" incl. system separator
100519	Composite tank Heaty 300 without head / empty hot water
100462-1	Mechanical seal for pump
100462-2	Seal set for pump hydraulics
100462-4	Pump set UWS Heaty Racun 300 Advanced / Advanced Plus
100481	Replacement filter for UWS Heaty Racun 300 Advanced / Advanced Plus (2 pieces)
100481-1	2-way head UWS Heaty Racun 300 Advanced / Advanced Plus
100481-2	Connection joint UWS Heaty Racun 300 / Advanced / Advanced Plus

7

Dismantling and disposal



CAUTION

The device may only be dismantled by authorized and qualified personnel who are familiar with the dangers.



NOTE

Regulations and laws

Observe the local regulations and laws on the disposal of environmentally harmful substances.

- The appliance may only be dismantled by authorised specialist personnel.
- Observe the safety instructions in the operating instructions in section „2 Safety instructions“ on page 10.
- Do not touch any live components.
- Wear suitable personal protective equipment.
- Only use suitable and tested lifting equipment.

Injuries can be caused by:

- Live components
- Heavy components that fall down after being released
- Sharp edges

7.1 Specialised personnel

Specialist personnel must observe the following points:

- Observe the safety instructions in this operating manual.
- Wear suitable personal protective equipment.
- Only use suitable and tested lifting equipment.
- Use suitable means of transport and keep the transport routes clear.
- Switch off the appliance before starting work and disconnect it from the power supply.

7.2 Disassembly

Proceed as follows to dismantle the device:

- 1 Switch off the device and disconnect the power supply from the mains as described in section „5.4 Switching off the device“ on page 44.
- 2 Discharge energy storage devices such as springs or capacitors, if present.
- 3 Make sure that any residual pressure has been released.
To do this, open the drain valves.
- 4 Disconnect the pipelines of the appliance from the heating or cooling system.
- 5 Empty the residual quantities into a drain.
- 6 If you want to store the appliance or take it out of operation, empty the appliance completely.
- 7 If you want to dispose of the appliance, dismantle the appliance into its components using suitable tools.

7.3 Disposal

Dispose of assemblies and operating materials properly and in an environmentally friendly manner.

Observe the statutory and company regulations.



Technical data

In this section you will find technical data on the device in general as well as on the applications and components used.

8.1 General data

Heaty Racun 300 Advanced Plus	
Item number	100481-SL
Max. Filling capacity*	3,000 l/h
Max. operating pressure	6 bar
Ø Circulation capacity in bypass with magnetic separator & filtration	Adjustable from 1,800 to 7,200 l/h
Ø Circulation capacity in the bypass for treatment and filtration	approx. 2,400 l/h
Capacity at 420 µS/cm to < 100 µS/cm**	9.360 l
Power supply	230 V / 50/60 Hz
Weight (incl. mixed bed resin filling)	approx. 143 kg
Contents Vadion pH-Control	63 l
Suitable for hot water up to 80 °C	✓
Bypassable	✓

8.2 Components

8.2.1 MAGella twister10

MAGella twister10	twister10
Art.-No.	100101
High-gloss filter housing made of V4A stainless steel	Stainless steel V4A
Filter basket with seal to increase dual filtration	✓
Pressure spring to increase dual filtration	D2
Max. flow rate	10 m ³ /h
Magnetic field strength (Gauss)	11x12,000
Shut-off valves (included in the scope of delivery)	2x 1 1/2"
Connections	1 1/2"
KFE drain valve (included in scope of delivery)	1/2"
Brackets for filters (included in scope of delivery)	✓
Vent shut-off with hose	1/4"
Max. Max. temperature	80°C
Max. Operating pressure	10 bar

Further information on the MAGella twister can be found in section „9.2 MAGella twister“ on page 58.

8.2.2 Circulation pump

Maximum operating pressure	8 bar
Ambient temperature	-20 °C to 40 °C
Maximum media temperature	95 °C
Maximum relative humidity	95 %
Maximum throughput	7.2 m ³ /h



Applicable documents

These operating instructions apply together with the following documents:

- Safety data sheet Vadion pH-Control
- Capacity calculator for filling devices,
see QR code in app or manufacturer's homepage:
<http://uws-technologie.de/services/berechnungstool/>
- Measured values and conversion tables,
see „9.1 Measured values and conversion tables“ on page 55-57
- Information on the dual filter,
see „9.2 MAGella twister10“ on page 58
- Quick guide to the changeover value,
see „9.3 Quick guide to the changeover value“ on page 60
- Terminal diagram for control unit,
see „9.4 Modbus address tree“ from page 62

9.1 Measured values and conversion tables

9.1.1 Corrosion rate

Oxygen, acids and dissolved salts cause corrosion in the heating or cooling system. The speed of corrosion depends on the amount of substances dissolved in the water, which can be assessed by measuring the conductivity.

The following reference values apply for estimating the corrosion rate with the help of conductivity:

Conductivity [$\mu\text{S}/\text{cm}$]	Corrosion rate
0–100	slowed down, as required by VDI2035
100–350	very slow
350–500	slowly
500–1.000	accelerated
1.000–2.000	strongly accelerated
>2.000	very strongly accelerated

9.1.2 Lime content and water hardness

The limescale content and water hardness can be roughly estimated by measuring the conductivity. The following table illustrates the relationships:

Conductivity [$\mu\text{S}/\text{cm}$]	Lime content [g/1,000 litres]	Classification of water hardness
<100	<35	desalinated
100	50	very soft
200–300	100-150	soft
400–500	200-250	medium hard
600–800	300-400	hard
900–1,000	450-500	very hard

The following table is used to determine the exact water hardness:



NOTE

This conversion is only applicable if the water is not softened and does not contain any chemical additives.

If the water is softened, it must be measured using the hardness drop method. Hand-held measuring devices do not provide meaningful values for softened water.

Conduc-tivity [μS/cm]	Hard-ness [°dH]	Hard-ness [°fH]	Lime content [g/1,000 l]	Conduc-tivity [μS/cm]	Hard-ness [°dH]	Hard-ness [°fH]	Lime content [g/1,000 l]
<100	<1	<2	<35	1,120	32	57	560
105	2	5	53	1,155	33	59	578
140	4	7	70	1,190	34	61	595
175	5	9	88	1,225	35	62	613
210	6	11	105	1,260	36	64	630
245	7	12	123	1,295	37	66	648
280	8	14	140	1,330	38	68	665
315	9	16	158	1,365	39	69	683
350	10	18	175	1,400	40	71	700
385	11	20	193	1,435	41	73	718
420	12	21	210	1,470	42	75	735
455	13	23	228	1,505	43	77	753
490	14	25	245	1,540	44	78	770
525	15	27	263	1,575	45	80	788
560	16	28	280	1,610	46	82	805
595	17	30	298	1,645	47	84	823
630	18	32	315	1,680	48	85	840
665	19	34	333	1,715	49	87	858
700	20	36	350	1,750	50	89	875
735	21	37	368	1,785	51	91	893
770	22	39	385	1,820	52	93	910
805	23	41	403	1,855	53	94	928
840	24	43	420	1,890	54	96	945
875	25	45	438	1,925	55	98	963
910	26	46	455	1,960	56	100	980
945	27	48	473	1,995	57	101	998
980	28	50	490	2,030	58	103	1,015
1,015	29	52	508	2,065	59	105	1,033
1,050	30	53	525	2,100	60	107	1,050
1,085	31	55	543	2,100	60	107	1,050

9.2 MMAGella twister10

This section contains illustrations and the characteristic curve of the built-in MAGella twister10.

9.2.1 Zeichnungen

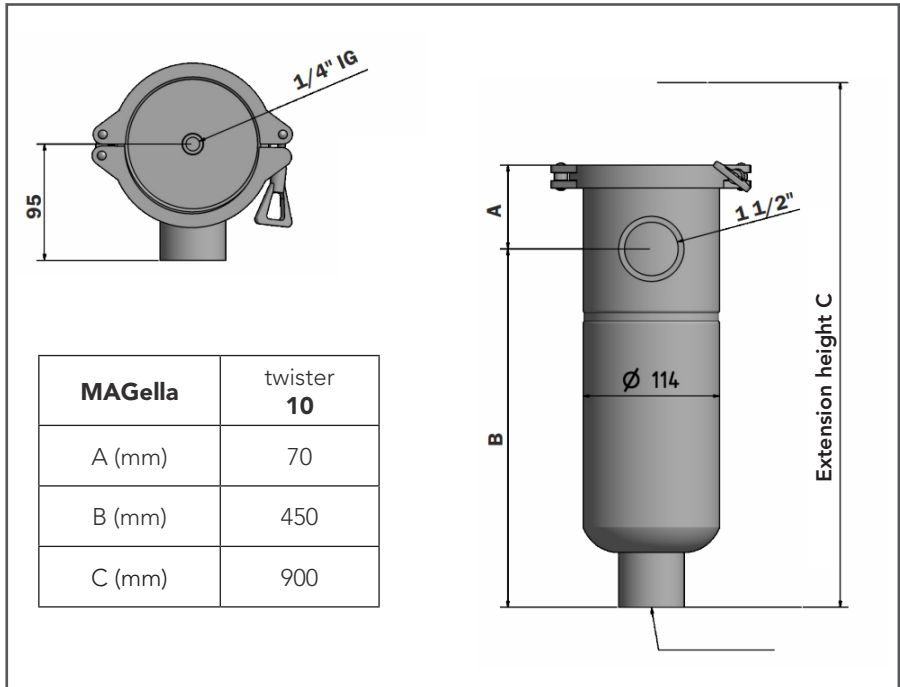

Fig. 9-9: Dimensions MAGella twister10

9.2.2 Characteristic curve

The flow resistance diagram of the MAGella twister10 shows the following characteristic curve:

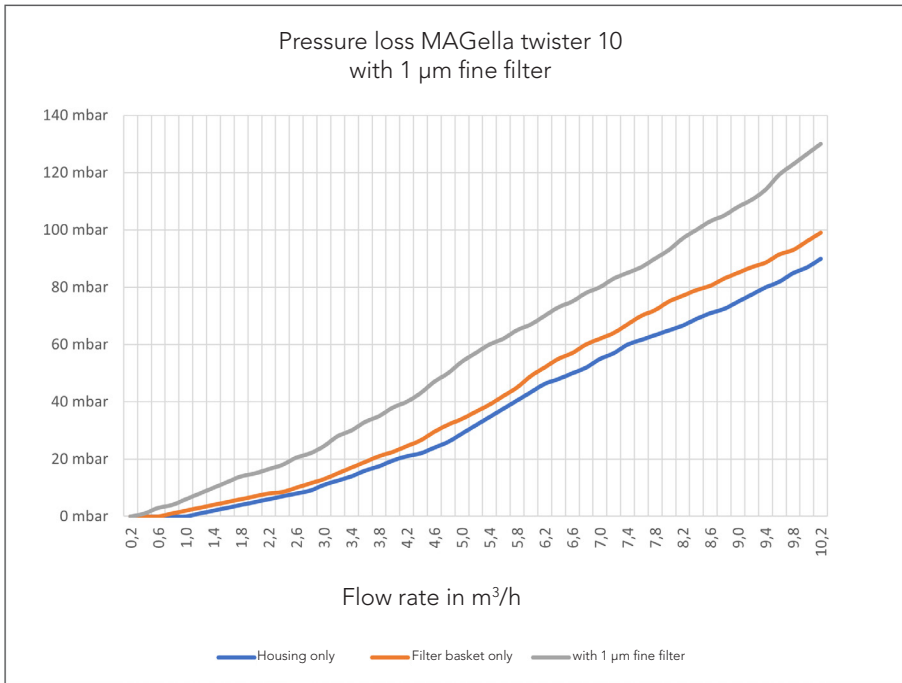



Fig. 9-10: Characteristic curve dual filter

9.3 Quick guide to the changeover value

GB ELECTRIC MOTOR ACTUATED BALL VALVE
D KUGELHAHN MIT ELEKTROMOTORISCHEM ANTRIEB
 EMV 110...
 SERIES 930



INSTALLATION INSTRUCTION AND USER'S MANUAL
 MONTAGEANWEISUNG UND BEDIENUNGSANLEITUNG

Installation should be carried out only by a qualified person!
 Die Montage darf nur vom Fachmann ausgeführt werden!

DIMENSIONS / ABMESSUNGEN

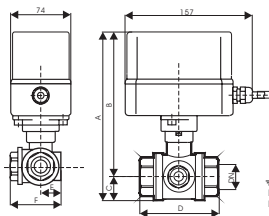

DIMENSIONS / ABMESSUNGEN								
G	DN	A	B	C	D	E	F	KV
1 1/2"	32	226	193	38	130	64	100	20
1 1/4"	40	239	200	39	150	70	115	37.2
2"	50	254	207	47	170	90	135	48.7

TYP / TIP	CODE	G	DN	Δ
930/410	10025	1 1/2"	32	4
930/410	10026	1 1/4"	40	5
930/410	10027	2"	50	7

***EMV 110 930/310 with relay / mit Relais**

TYP / TIP	CODE	G	DN	Δ
930/310	10030	1 1/2"	32	4
930/310	10031	1 1/4"	40	5
930/310	10032	2"	50	7

ELECTRICAL CONNECTION / ELEKTRISCHER ANSCHLUSS

EMV 110...410 (230VAC)
 EMV 110...413 (24VAC)

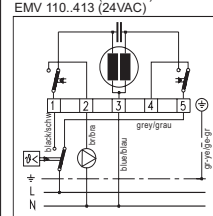

BUILD-IN ROOM / EINBAURAUM

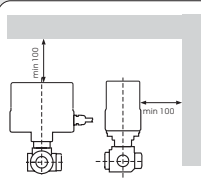

TECHNICAL DATA / TECHNISCHE DATEN

Mains connection / Nennspannung: 230 V~, 50Hz
 * 24 V~, 50Hz

Power consumption / Nennleistung: 3,5 W max

Rotation time / Rotationszeit: 105s / 90°

Microswitch rating / Belastung der Mikroschalter: 5(1)A, 250 VAC

Actuator protection class / Antriebsschutzart: IP 54

Terminals / Anschlussklemmen: 0,5...1 mm²

Cable length / Kabellänge: 1500 mm

Ambient temperature / Umgebungstemperatur: 0...50°C

Fluid temperature / Temperatur des Fluids: 0...110°C max

Output torque / Ausgangsmoment: 25 Nm

Fluids and gasses (water, nonaggressive media) up to 16 bar.
 Flüssige und gasförmige Medien (Wasser, nicht aggressive Fluide) bis zu 16 bar.

***EMV 110 930/310 with relay / mit Relais**

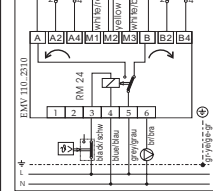

HYDRAULIC INSTALLATION - RECOMMENDED INSTALLATION OF THE ELECTRIC ACTUATED BALL VALVE / SCHEMA DER MASCHINENINSTALLATION EMPFOHLENER EINBAU DES KUGELVENTILS MIT ELEKTROMOTORANTRIEB

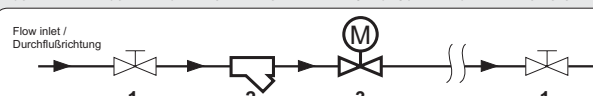

1 manual stop valve / Manuelle Absperrvorrichtung
 2 strainer with the mesh width 0,65 mm / Reinigungsfiter Y (für detaillierte Informationen bitte rufen Sie uns an / liefern in Abmessungen von 1 1/4" bis 2")
 3 motor actuated ball valve series EMV 110... Elektromotorantrieb mit Kugelventil EMV 110...

IMPORTANT !
 To extend the long term performance of the motorised ball valve it is recommended that a strainer is situated prior to the valve. By installation must be observed to according to relevant local standards.

WICHTIG!
 Um die Lebensdauer des Ventils zu erhöhen und Beschädigung der Dichtungen durch mechanische Teile in der Installation zu verhindern, wird der Einbau eines Reinigungsfilters empfohlen. Die einschlägigen VDE+TÜV-Vorschriften sind zu beachten.

BUILD-IN POSITION / EINBAULAGE

PRIORITY / VORRANGIGE EINBAULAGE

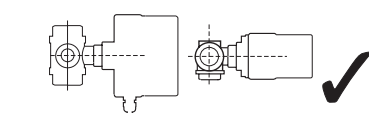

ALLOWED / MÖGLICHE LAGE

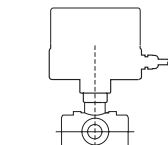

NOT ALLOWED ! UNERLAUBTE LAGE !

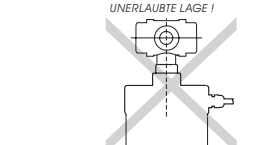

Fig. 9-11: Quick guide to changeover value, page 1

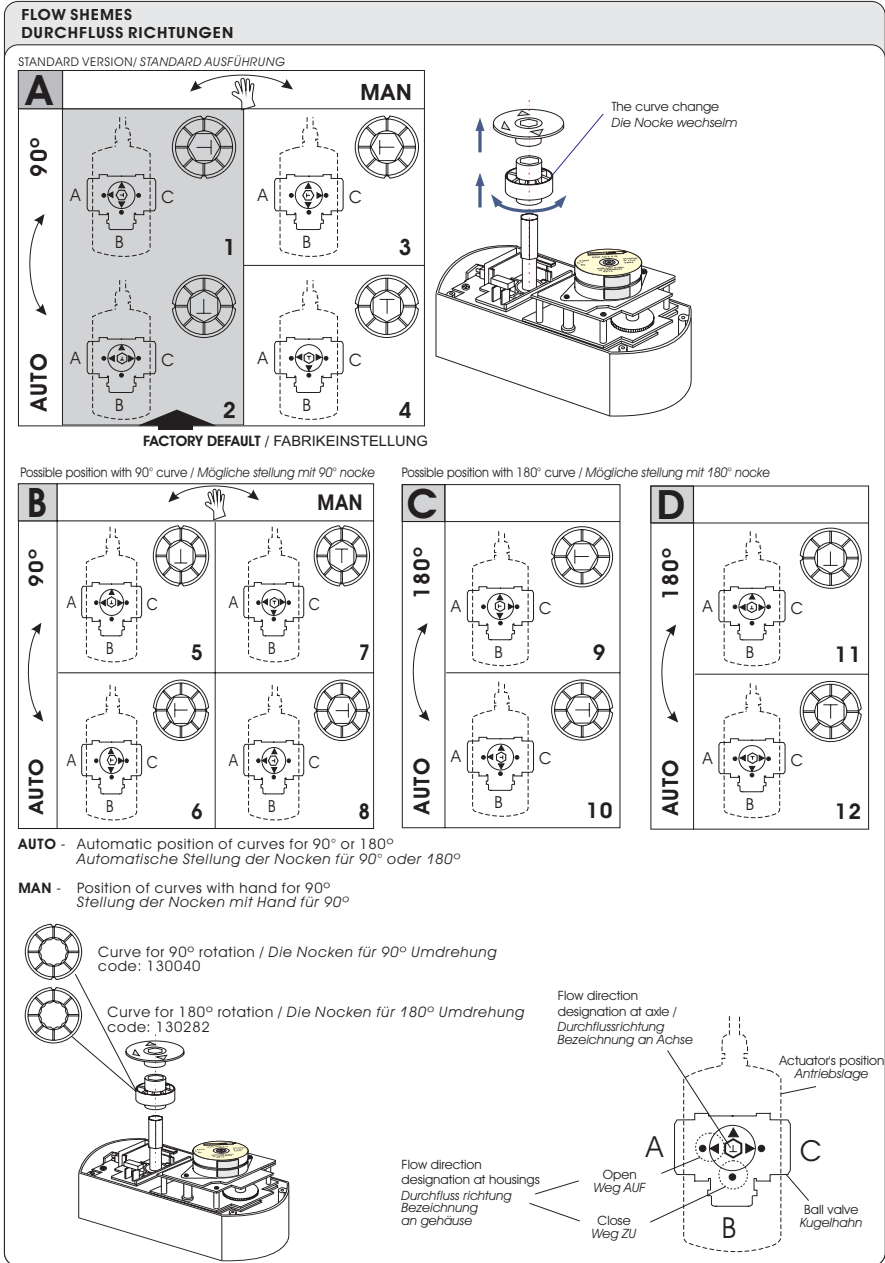

Fig. 9-12: Quick guide to changeover value, page 2

9.4 Modbus address tree

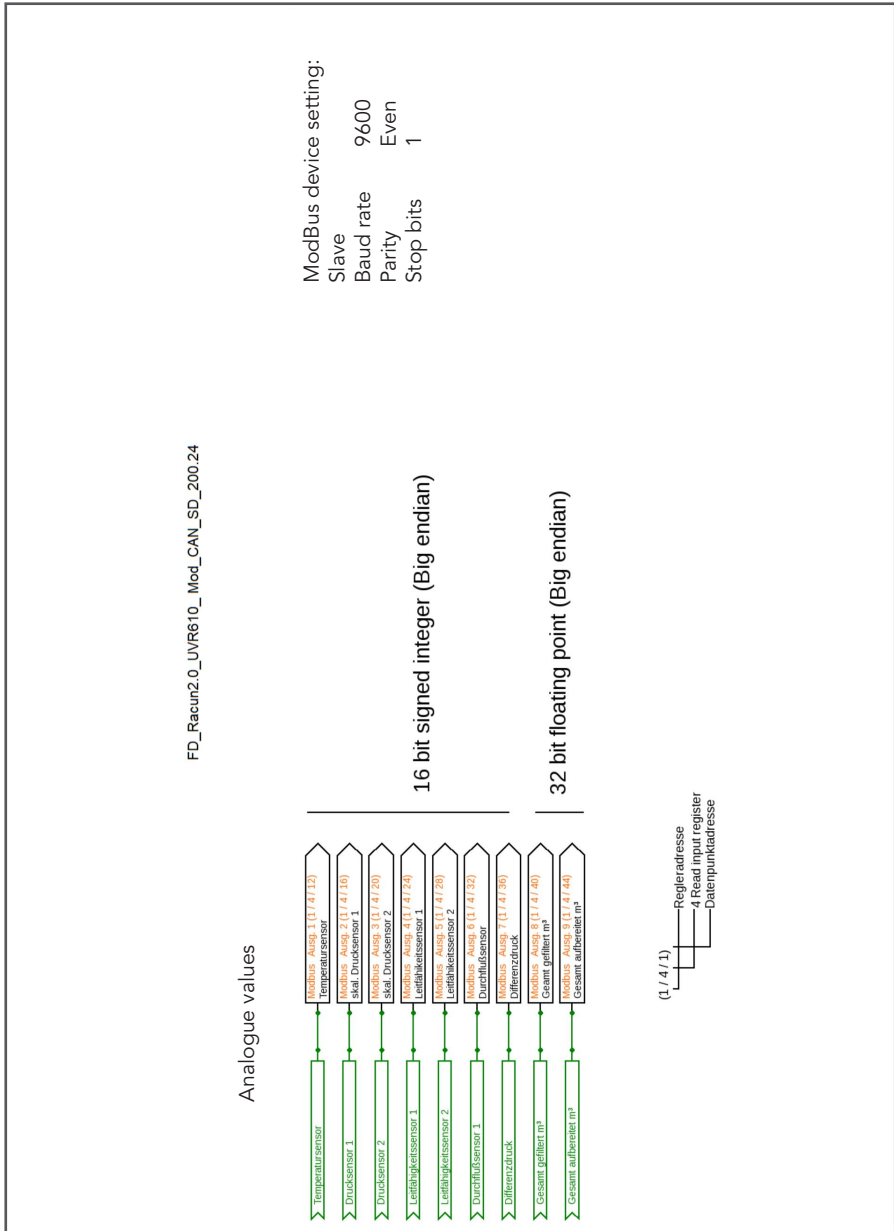
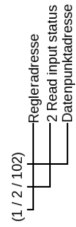
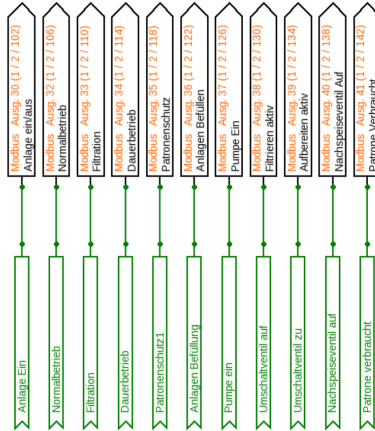

Fig. 9-13: Analogue Modbus values

FD_Racun2.0_UVR610_Mod_CAN_SD_200.24

Operating messages



16 bit signed integer (Big endian)

Fault messages

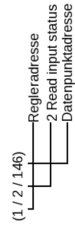
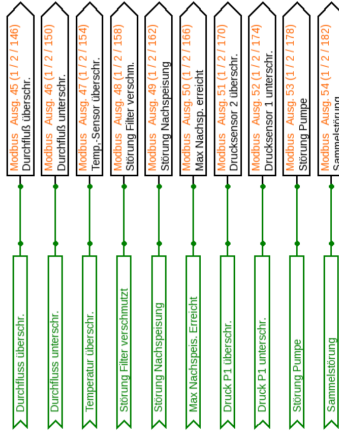

Fig. 9-14: Operating/fault messages

10

List of illustrations

Fig. 3-1: Overview of the components of the device	18
Fig. 3-2: Detailed views	19
Fig. 3-3: Components of the touch display	21
Fig. 3-4: Components of the touch display	21
Fig. 3-7: The dual filter in dismantled condition	22
Fig. 4-8: Bypass connection diagram	29
Fig. 9-9: Dimensions MAGella twister10	58
Fig. 9-10: Characteristic curve dual filter	59
Fig. 9-11: Quick guide to changeover value, page 1	60
Fig. 9-12: Quick guide to changeover value, page 2	61
Fig. 9-13: Analogue Modbus values	62
Fig. 9-14: Operating/fault messages	63

Enter the date of commissioning here: ___/___/___

Name of the installer: _____

Telephone number of the installer: _____

EC-Declaration of conformity



EC Declaration of Conformity



We hereby declare that the machine designated below, in its design and construction and in the version placed on the market by us, complies with the basic safety and health requirements of **EC Directive 2006/42/EC** of 17 May 2006. This declaration shall lose its validity if the machine is modified without our agreement.

Subject of the declaration: Heating water filling device Heaty Racun 300 Advanced Plus

Item number: 100474-SL
Year of manufacture: 2022

Manufacturer: UWS Technologie GmbH
Sudetenstraße 6
91610 Insing

The subject matter of the declaration described above complies with the requirements of other relevant harmonisation legislation:

EMC Directive (2014/30/EU) of 26 February 2014
RoHS Directive (2011/65/EU) of 8 June 2011

The following harmonised standards and technical specifications have been applied:

EN ISO 12100: 2010	Safety of machinery - General principles for design - Risk assessment and risk minimisation
EN 809: 1998 + A1: 2009 + AC: 2010	Pumps and pump units for liquids -General safety requirements
EN 60335-1: 2012 + AC: 2014 + A11: 2014 + A13: 2017 + A1: 2019 + A2: 2019 + A14: 2019	Household and similar electrical appliances - Safety - Part 1: General requirements

Authorised person for compiling the technical documentation: Mario Milković, see manufacturer's address

Insing, 24.09.2021
Ort, Datum

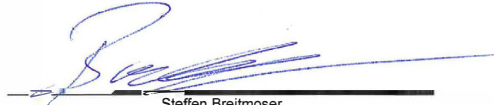
Steffen Breitmoser
(Geschäftsführung)





OUR WATER. SAFE.

Your contact:

© UWS Technologie GmbH – All rights reserved

Version 1.0

Reprinting, even of individual passages, is prohibited. The copyright and all rights are owned by UWS Technologie GmbH. Translation, duplication, storage and distribution, including transfer to electronic data carriers and storage in electronic media, is prohibited and punishable without prior written approval.

No claims can be made based on the information or illustrations provided.
We reserve the right to make changes in technology, form and equipment.
No liability is assumed for errors and misprints.

