

Heaty Complete PROfessional

Cloud-enabled IoT replenishments

Heaty Complete PROfessional

Heaty Complete PROfessional XL



1	Installation and operation	3
	Installation	3
2	Registration in the cloud portal	8
3	Heaty Complete PROfessional menu navigation	12
	Menu navigation of the display	12
	Additional information about the menu	16
4	Cartridge change	18
	Cartridge change Heaty Complete PROfessional series	18
	Handling Mixed Bed Resin	17
5	Technical data	19
	Capacities	19
	Dimensions	21
6	Operating instructions for filling combination	22
	Area of application	22
	Execution	22
	Installation	22
	Pressure reducer setting	23
	Filling the heater	24
	Checking the system separator	25
	Changing the system separator cartridge	26
	Malfunctions - Troubleshooting	27
	Technical data filling combination	28
	Filling combination dimensions	29
7	Spare parts	30
	Spare parts Heaty Complete PROfessional	30
	Spare parts filling station wagon	31
	Declaration of Conformity Heaty Complete PROfessional	32
	Declaration of Conformity Heaty Complete PROfessional XL	33
Appendix	Menu history Heaty Complete PROfessional	34/35

1 Installation and operation

Installation

Please assemble the Heaty Complete PROfessional according to the following scheme.

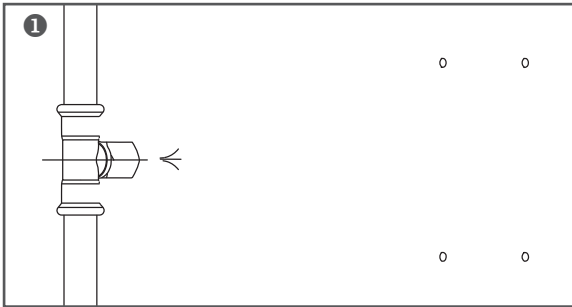

1
Rinse the connection line
free of dirt particles

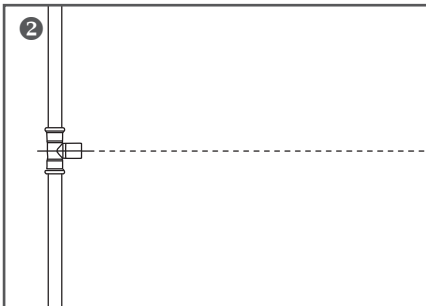

2
Transfer the center of
the connection to the
wall

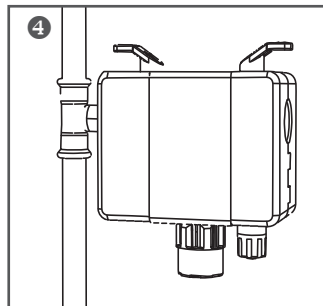
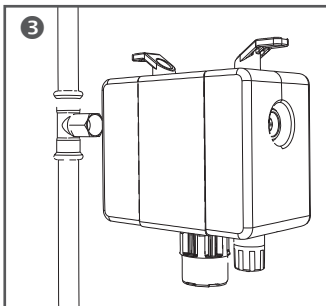

3 + 4
Now install the
system separator

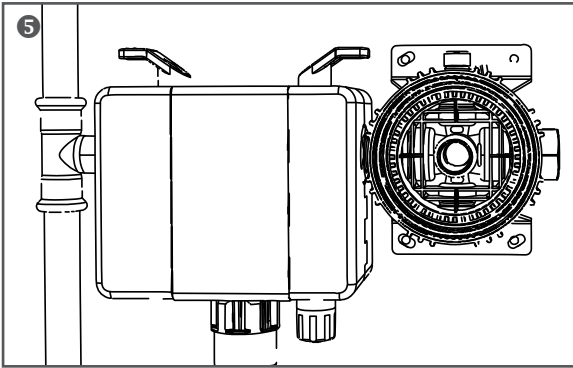

5
Screw the connection flange to the system separator and mark the drill holes

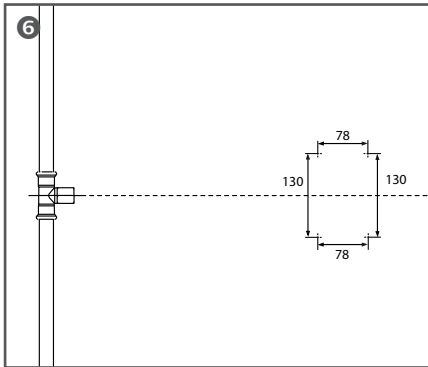

6
Hole pattern

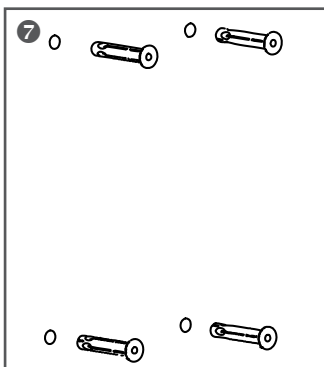

7
Insert the dowels

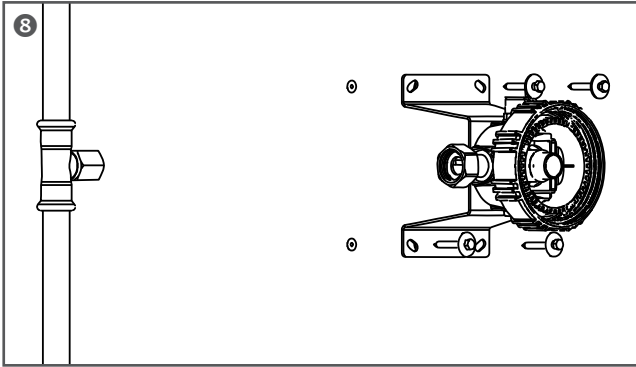

8
Screw the connection flange with the screws provided

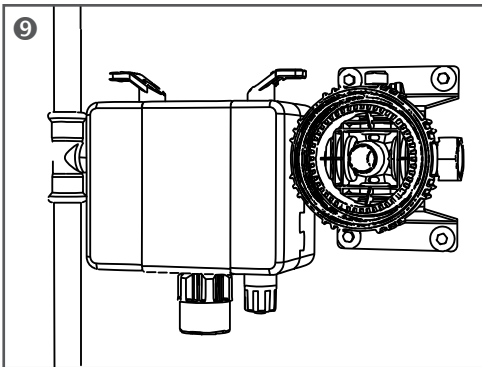

9
Now screw the connection flange to the system separator



NOTE

The assembly can also be done in reverse order:

1. Screw the system separator to the connection flange
 2. Install the system separator on the pipe
 3. Screw the connection flange onto the previously drilled holes
-



NOTE

Please note that the water refill must be connected to the drinking water before a water softener.

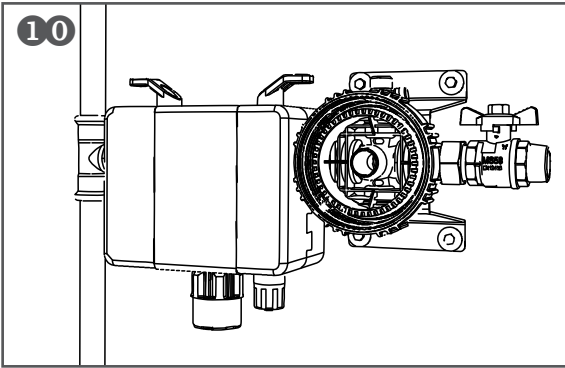

10
Screw the ball valve onto the outlet side of the connection flange

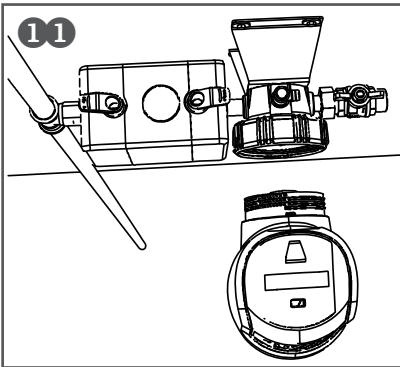

11
Screw the Complete PROfessional to the connection flange

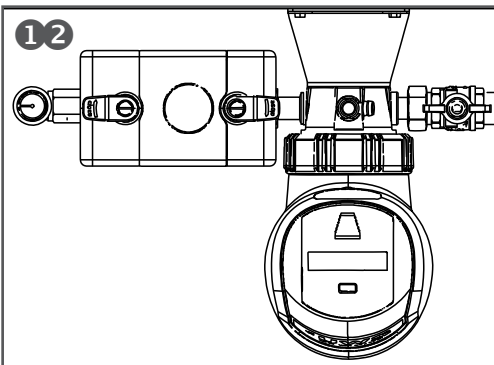

12
Finished

- a. Please pay attention to the flow direction for all components.
- b. The vent is attached to the top of the connection flange. The blind plug must be mounted on the opposite side.



NOTE

Close vent screws after opening

The bleeder screws are after a possible. The opening must be closed again in any case, otherwise uncontrolled water leakage may occur!
No tools are required to operate the bleeder screw.

Installation diagram

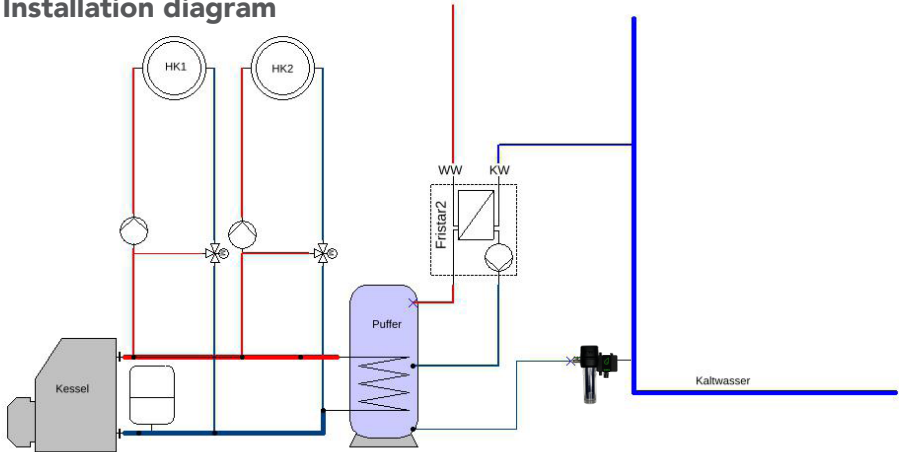

DANGER

If the system contains automatic water make-up, pressure maintenance systems or systems that can generate pressure surges, the UWS Complete PROfessional must not be used.



NOTE

Please note that the water refill must be connected to the drinking water before a water softener.

2

Registration in the cloud portal

How to register your Heaty Complete PROfessional

The heart of the cloud-enabled replenishment is the cloud portal (<https://www.uws-master.de/portal/heatycomplete>), which provides a central interface for all relevant data and messages. From monitoring refills to notification of events that require intervention, the portal provides a user-friendly platform for HVAC staff and operators. In addition, push notifications are sent for all events that require intervention. This makes it possible to identify and resolve potential problems at an early stage, preventing costly downtime and optimizing operational processes. For example, the replacement of a cartridge can be planned well in advance.

Registration of the refill via the QR code on the device or on the packaging

Simply scan the QR code. You will be redirected to the registration page (Image 1) of the cloud portal and the serial number will be automatically transferred (in the background). Create a customer account there ("Create new account") or log in ("Log in") if you already have an account. After logging in or registering, the message "The serial number is available and can now be registered" appears in the upper area of the next page (Figure 2). Then enter the desired data there. In the reference field you can store all information to easily assign your installed Complete PROfessional, e.g. customer address or construction site address. Important: The two free refill cartridges will be sent to the address provided here. **Finished!**

Registration via the website

You already have an account:

Log in using the "Registration" button. In the dashboard (Image 3) you will find the button "Register new device" at the top left. After one click (picture 4) you can enter the serial number there. On the next page (Image 2) the message "The serial number is available and can now be registered" appears at the top. Then enter the desired data there. In the reference field you can store all information to easily assign your installed Complete PROfessional, e.g. customer address or construction site address. Important: The two free refill cartridges will be sent to the address provided here. **Finished!**

You don't have an account yet:

Click on the button "Create new account". Enter all required data there (Image 5) and click on "Register". After clicking you can enter the serial number there (Image 4). On the next page (Image 2) the message "The serial number is available and can now be registered" appears at the top. Then enter the desired data there.

In the reference field you can store all information to easily assign your installed Complete PROfessional, e.g. customer address or construction site address. Important: The two free refill cartridges will be sent to the address provided here. **Finished!**

Important: When you register your account, you will receive an email with a confirmation link. This is valid for 2 hours.

By registering your device in the UWS portal (<https://www.uws-master.de/portal/heatycomplete>), you can access the following functions online:

- **Complete package:** 5-year Complete PROfessional Package including 2 dessert cartridges and cloud connection. The status of the cartridge and the number of You can view the cartridges that have already been shipped in the dashboard (Image 3)
- **Alarm message in case of pressure loss or leakage:** The system is equipped with an intelligent alarm mechanism that immediately informs you about pressure loss or leaks to take quick action.
- **Alarm message by email from the UWS portal:** In addition to the alarm messages on site, you will be informed of any disruptions or problems by e-mail via the UWS portal so that you can react quickly. To do this, the option 'Send e-mail to me in the event of a fault' (dashboard top right) must be activated. (Image 3)
- **Leakage protection:** The leakage protection system provides reliable protection against unexpected leaks in order to minimise possible damage and ensure the safety of your surroundings. The leakage protection is determined and set on the device using three parameters > see chapter 3.
- **Daily pressure measurement:** The system performs daily pressure measurements to ensure constant monitoring of system integrity and detect potential problems at an early stage.
- **Continuous pressure measurement including automatic replenishment in the event of a pressure drop:** In addition to continuous pressure monitoring, the system offers automatic replenishment functions to regulate the pressure as required and ensure consistent performance.
- **Documentation** of the amount of treated and untreated water via integrated water meter
- **Daily status report on UWS Portal:** You receive daily status reports via the UWS Portal to provide a detailed overview of the operating status of your system and enable effective maintenance planning.
- **Logfile:** You can read all the activities of the Heaty Complete PROfessional in the log files.

Important

The Complete PROfessional automatically connects to the UWS master cloud via the integrated eSim module as soon as the terms and conditions have been confirmed on the device. You do not need to take any further steps to set up the communication connection to the cloud.





Heaty Complete PROfessional und Advanced Serie Portal

Registrieren Sie Ihre Heaty Complete Advanced Nachspeiseeinheiten (Heaty Complete PROfessional coming soon) und profitieren Sie von der vollständigen Nutzung des Funktionsumfangs. Wenn Sie auch die Kundendaten eingeben, bekommen Sie automatisch eine E-Mail von UWS, wenn die Kartusche nach zwei Jahren verbraucht ist. Zudem erhalten Sie und Ihr Kunde eine Garantieverlängerung auf 5 Jahre.

SHK-Betriebe nehmen durch die Registrierung auch automatisch am Bonusprogramm für die Heaty Complete Advanced teil.

Wenn Sie schon ein Konto haben:

Anmeldung

Sie haben noch kein Konto?

Neues Konto anlegen

Figure 1

Die Seriennummer *F65250868 ist verfügbar und kann jetzt registriert werden.

Referenz

Bitte füllen Sie dieses Feld, damit Sie dieses Gerät bei Fehlermeldungen, Alarmen und Kartuschenversand (nur PROfessional) zuordnen können.

Sie können z. B. eine Auftragsnummer, Kundennummer, Adresse usw. eingeben.

Heaty Complete registrieren

Figure 2

Neues Gerät registrieren E-Mail an mich senden bei Störung

→ Bonusprogramm Advanced | → Professional Package

Registrierte Heaty Complete-Einheiten

Legende für Status (nur PROfessional-Geräte)

- 🟡 keine Datenverbindung
- 🟢 aktive Datenverbindung
- 🔴 kritischer Fehler, Handlungsbedarf
- 🟡 keine Daten in den letzten zwei Tagen
- 🕒 Historie/Verlauf
- 🟡 unkritischer Fehler

100 Einträge anzeigen Suchen

Seriennummer	Referenz	Modell	Status	PRO Pack	Registrierungsdaten
2022184001	Max Mustermann	Complete PROfessional	🟢	0/2	23
2024162655	Heizkreis Blogas	Complete PROfessional	🟡	0/2	23
2024035197	Agrarstraße 22, 91541 Rothenburg	Complete PROfessional	🟢	0/2	23
2020030029	Hotel Sonne	Complete PROfessional	🟡	0/2	23
2020030028	Max at Home	Complete PROfessional	🟢	0/2	23
2020030027	Max Mustermann	Complete PROfessional	🟡	0/2	23

Figure 3

Um Ihre Heaty Complete registrieren zu können, müssen wir vorab die Seriennummer überprüfen.

Seriennummer

IMSI (nur Modell Complete PROfessional)

[Seriennummer prüfen](#)

Figure 4

Bitte erstellen Sie ein Kundenkonto, damit wir Ihnen die registrierten Heaty Complete entsprechend zuordnen können.

Mit der Erstellung Ihres Accounts nehmen Sie automatisch am Bonusprogramm zur Heaty Complete PROfessional und Advanced Serie teil. Pro 15 registrierter Heaty Complete erhalten Sie das Baustellenradio PerfectPro UBOX 400R. Weitere Details zum Bonusprogramm finden Sie unter <https://uws-technologie.de/bonusprogramm>.

Account

Figure 5

3 Heaty Complete PROfessional menu navigation

Menu navigation of the display

The complete menu history can be viewed in Appendix 1.

Menu level 1

**Please accept Terms
and Conditions**
V OK

This message informs you that you must read and confirm the terms and conditions. Only after confirmation can data be sent to the UWS Master Cloud.

**Please
register online**

This message appears if the Complete PROfessional has not yet been registered in the UWS MasterCloud.

Cartridge 100%
V 733 days

The capacity indicator shows you the cartridge's lifespan in percent. The minimum shelf life (lifespan) of the cartridge is displayed in days.

System pressure
V bar

Current system pressure on the heating side.

Refill?
V OK

This function also allows you to manually initiate the refilling process. If the capacity of the cartridge has already been exhausted, water can still be added. To do this, you must hold down the "OK" button for the desired amount.

**System
vent?** OK
V

This can be used to carry out an initial filling/partial filling of the heating system. The Complete PROfessional is based on the set values "target pressure" and "make-up pressure". The set target pressure is maintained for 30 minutes without a leakage alarm being issued.

**Replace
cartridge?** OK
V

If the cartridge is used up, it can be replaced via this menu item. Follow the instructions on the device.

Meter reading
V 599,4 l

Total water volume (treated and untreated) recorded by the Complete PROfessional.



Access to system settings.

Menu level 2



The leakage protection of the Complete PROfessional can be controlled via three parameters:

- Quantity in liters per refill (max. refill quantity)
- Duration of refill in minutes (max. refill time)
- Total number of refills per day (refills per day).

If one of these parameters is exceeded, a warning message is issued and the refill process is stopped.

Menu level 2

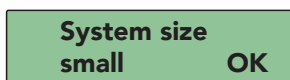

Fixed presets (recommended by the manufacturer) for small system sizes:

- Max. refill quantity: 1 liter per day
- Max. refill time: 1 min
- Refills per day: 1

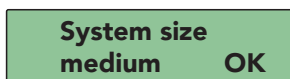

Fixed presets (recommended by the manufacturer) for medium system sizes:

- Max. refill quantity: 2 liters per day
- Max. refill time: 2 min
- Refills per day: 2

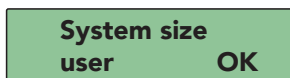

The three parameters can also be set individually via this menu item:

- Max. refill quantity per day [1-300 liters]
- Max. refill time: [1-60 min]
- Refills per day: [0-30 per day]

menu level 4

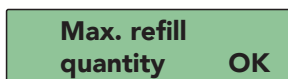

How many liters should be added at most per refill.



Maximum refill time per refill.

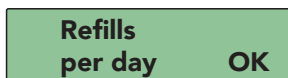

How often maximum refills should be made per day.

Menu level 2

**Pressure
Settings** **OK**

Entrance to pressure adjustment.

Menu level 3

Maximum pressure
OK

Maximum pressure of the heating system.
Factory setting: 3.0 bar [2.5-6 bar]

Target pressure
OK

Target pressure up to which automatic replenishment occurs.
Once the pressure is reached, the refill is stopped. The target pressure must be at least 0.5 bar below the maximum pressure.
Factory setting: 1.0 bar [0.8-3.5 bar]

Make-up pressure
OK

System pressure at which the water make-up starts automatically.
Replenishment takes place until the target pressure is reached.
The make-up pressure must be at least 0.1 bar below the target pressure.
Factory setting: 0.8 bar [0.9-1.4 bar]

Menu level 2

System info
OK

Access to system information.

Menu level 3

Device type
PROfessional

The device type is displayed here.

Serial number:
20242353654 OK

The serial number will be displayed here.

Unprocessed
0,1 l

Counter for the amount of water that is added untreated to the heating system via the menu item "Top-ups?".

Firmware version
V. 0. 0. 055

Firmware of the PROfessional microcontroller.

IMSI number:
V 90140510005684

Number of the built-in module for communication.

IOT: BG95M3LAR02
V A04_01.001.01.001

The firmware of the built-in module for communication.

IOT signal
V 14,99

In this display you can read the signal strength of the IoT signal.

Additional information about the menu:

OK = Execute V = next menu item

Heaty Complete PROfessional menu navigation

Menu navigation of the display

The complete menu history can be viewed in Appendix 1.



NOTE

If the LED lights up red (also indicated by an acoustic signal), there is an error message. The following messages may occur:

Cartridge used up	Cartridge capacity exhausted, please replace cartridges
Temperature > 40°C	The water temperature is higher than 40°C, temperature must be reduced
Check entry	No water flow detected, please check the water inlet
Leakage protection Water volume	Too much water has been added, please check the heater for possible leaks
Leakage protection time	Water has been added for too long, please check the heater for possible leaks
Leakage protection Filling	Too many fillings per day, please check the heater for possible leaks
Pressure too high – maintenance	Please check the pressure conditions of your system
Screw in cartridge	Transparent housing of the cartridge is not screwed on properly, please screw the housing on properly

Using the menu, you can easily view the resin capacity and the amount of treated or untreated water, as well as conveniently and menu-guidedly replace the cartridge. You can also set the parameters for automatic refilling and leakage protection.



DANGER

Always check the cartridge seal after replacing a cartridge.

Menu item "Replenish?"

This function also allows you to manually initiate the refilling process. If the capacity of the cartridge has already been exhausted, water can still be added. To do this, you must hold down the "OK" button for the desired amount.



DANGER

If you do not have a replacement cartridge on hand, refilling is still possible. However, the refill water will then not be treated in accordance with VDI 2035. You may lose as a result. Warranty claims or may damage the heating system. Therefore, you should only use this in absolute emergencies. The amount of water added but not treated is recorded by a separate meter.

4 Cartridge change

Cartridge change Heaty Complete PROfessional series

When should the cartridge be changed?

The cartridge must be changed when the corresponding display (including acoustic signal) appears in the menu.



DANGER

The cartridge must be replaced after 2 years at the latest!

Changing the cartridges in the PROfessional series is child's play

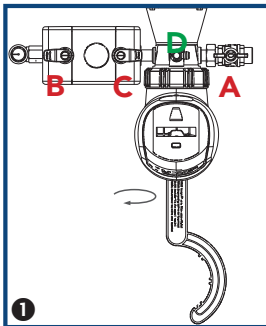

- 1 Close the inlet B and C) and open the vent (D).
Then turn the Key (included) on the cover clockwise. (A, Key included) on nut

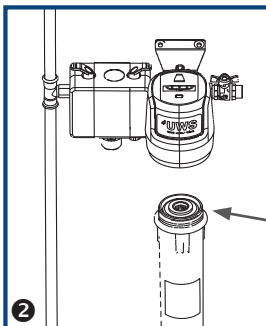
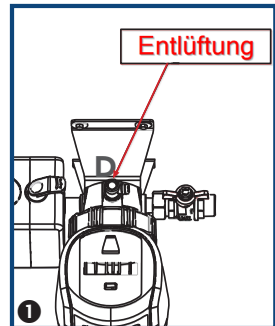

- 2 Remove the used cartridge and dispose of this. Then insert the new cartridge. (Art.No. 100854; XL = 100855)
Replace the O-ring and rub it with the supplied silicone grease bag.

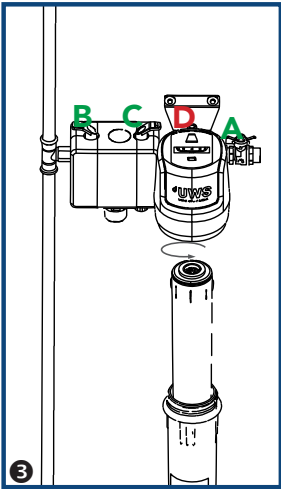

③ Close the cartridge container with the key counterclockwise.

Now you can connect the inlet (B and C) again open and then close the vent (D) again close.

Now you can also close the inlet (A) again open.



NOTE

Screw it on by hand and tighten it with a tool until it stops, using little force!



NOTE

Handling Mixed Bed Resin

When handling the mixed bed resin, please note the following points:

- Do not store the mixed bed resin openly, otherwise it will lose capacity.
 - Use the outer packaging of the refill pack to dispose of the replaced mixed bed resin.
 - Change the mixed bed resin over a drain so that the water separated from the replaced mixed bed resin can drain away.
 - Wear appropriate personal protective equipment (safety glasses, gloves).
-

5 Technical data

Heaty Complete	PROfessional	PROfessional XL
article number	100390	100391
connection thread	3/4" AG for ÜWM flat sealing	
max. operating temperature	40 °C	
max. filling capacity*	65 l/h	120 l/h
max. operating pressure	6 bar	
capacity at 420 µS/cm**	120 l	225 l
pressure reducer	adjustable	
electrical connection	USB port 5 V	
Built-in length	340 mm Flat sealing to flat sealing with filling combination and shut-off valve	

capacities*

* Dependent on system and network pressure.

** The capacity specifications are based on the ideal case (12°dH / 21°fH). Deviations may occur due to application errors, water quality and temperature.

Heaty Complete	PROfessional	PROfessional XL
At 1°dH / 2°fH	1.400 l	2.700 l
At 12°dH / 21°fH	122,5 l	225 l
At 20°dH / 36°fH	70 l	135 l

Remark

The capacity depends on various parameters such as the water temperature, the chemical composition of the water or the flow pressure. For an accurate determination, a water analysis of the raw water must be carried out. The values given here always refer to the optimal case and do not represent a binding guarantee.

Dimensions

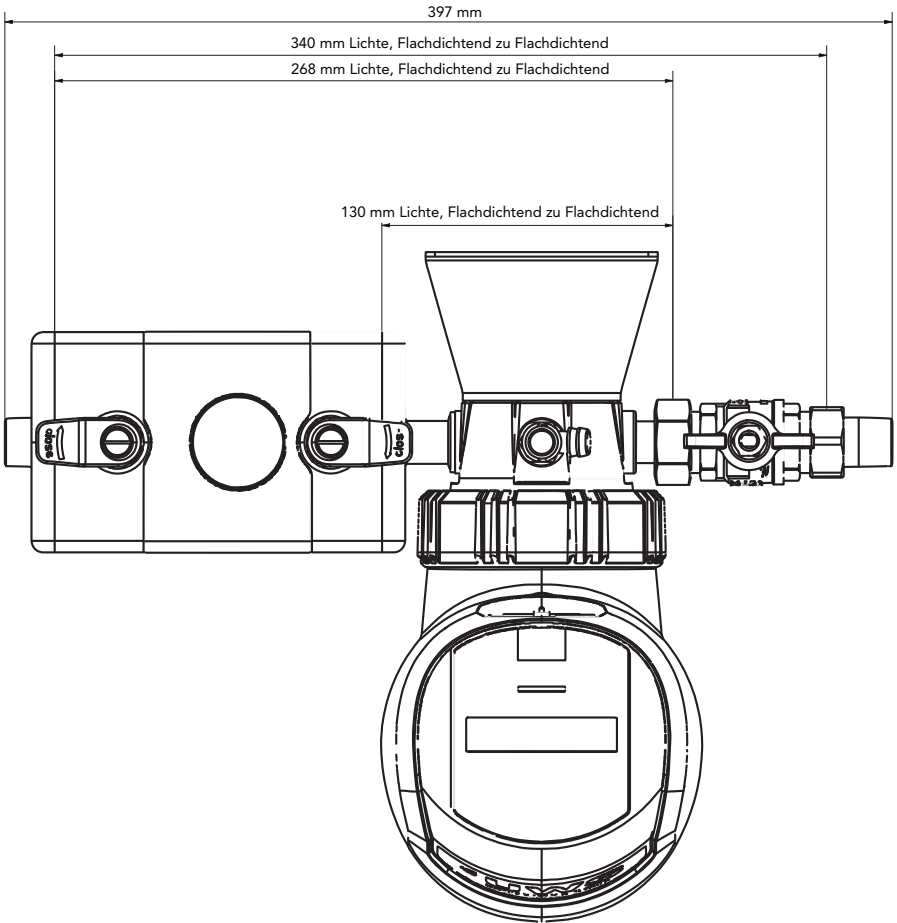



Operating instructions for filling combination

Area of application

The filling combination BA is used to automate the filling process in hot water heating systems.

The built-in system separator BA according to EN 1717 prevents the heating water from flowing back into the drinking water pipe. In this combination, the direct fixed connection to the heating system is permitted according to EN 1717.

The integrated pressure reducer ensures the correct and constant pressure of the system.

Execution

The BA filling combination consists of integrated inlet and outlet shut-off valves, BA system separator according to EN 1717, drain funnel, test devices, pressure reducer, dirt trap and pressure gauge. Pressure reducer adjustment range between 1 and 5 bar. Screw connections on both sides.

Housing made of pressed brass. Internal parts and drain funnel made of high-quality plastic and NBR.

The BA filling combination contains all components specified in EN 1717 to connect the drinking water pipe directly to the heating circuit.

The built-in pressure reducer ensures a constant set outlet pressure so that the heating system is protected from unwanted overpressure during the filling process.

After completing the filling and venting process, the integrated shut-off valve should be closed to prevent uncontrolled refilling of the heating system.

Installation

The connection line of the filling combination BA must be designed in such a way that no stagnation occurs.

Before installing the filling combination BA, the pipeline must be carefully flushed. The fitting must be installed in the pipe in such a way that the drain funnel points vertically downwards so that the escaping water can drain away with a free gradient.

An easily accessible installation location simplifies maintenance and inspection. Care must be taken to ensure that the installation location is protected from flooding and frost and is well ventilated. The drain line must be provided with sufficient capacity.

In order to ensure long-term and flawless functioning, we recommend installing a drinking water filter in accordance with EN 13443, Part 1 immediately after the water meter.

The maintenance intervals for the BA Plus filling combination must also be observed. To connect the funnel to the sewage system, the applicable standard EN 12056 must be observed.

Pressure reducer setting



NOTE

Please note that the pressure reducer of the filling combination BA is set to 1.5 bar at the factory. Please remember: The inlet pressure must be at least 1 bar higher than the desired system pressure.

The pressure reducer can be adjusted as follows:

❶ If a lower system pressure than 1.5 bar is desired, loosen the locking screw in the adjustment handle of the pressure reducer and turn it in the direction of the minus arrow (-) to the starting position.

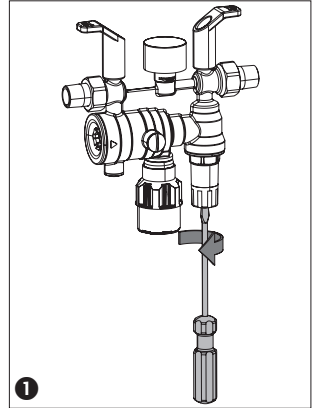

❷ Once the appropriate starting situation is reached, open the inlet valve (1) to pressurize the fitting, the outlet side (2) remains closed.

Now turn the adjustment handle towards plus (+) to increase the filling pressure.

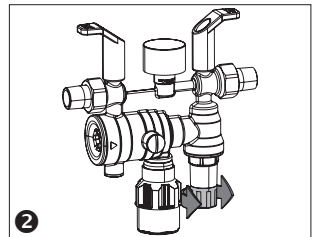

❸ Now set the desired system pressure by turning the adjustment handle SLOWLY (due to the sensitivity of the pressure gauge) in the plus (+) direction.

Once the desired pressure value has been reached, tighten the locking screw again. Now you can open the outlet valve (2).

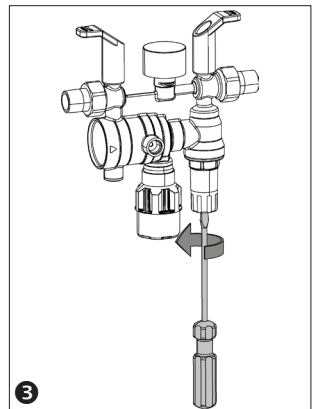

Filling the heater

To start the filling process, both filling combination shut-off valves (B & C) as well as the shut-off valve after the water meter (A) must now be opened. The differential pressure-controlled refill then automatically begins filling until the desired pressure is reached.

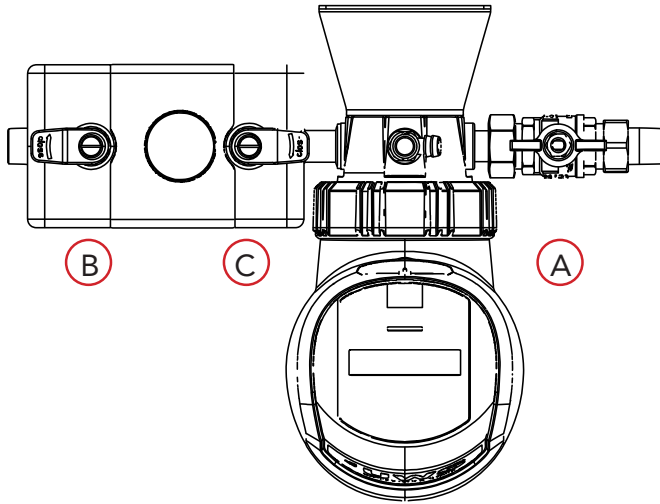

Close all shut-off valves (A-C) after completion of the automatic filling process to prevent uncontrolled refilling.

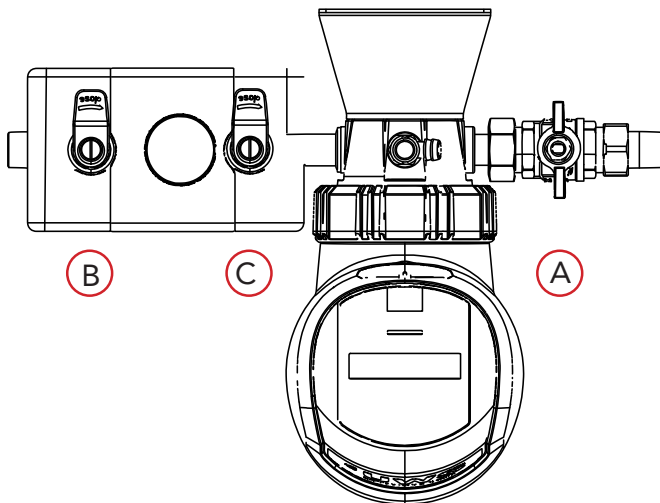



NOTE

To ensure that the heating system is filled completely and quickly, it must be vented during the filling process!

Please note that the last 0.5 bar before the set value is reached may take a longer time.

If you fill an empty system, please ensure that you do not exceed a filling capacity of 2.5 l/min.

If the Heaty Complete PROfessional is to be used permanently as an automatic make-up unit, leave the ball valves in the open position!

Checking the system separator

Remove the pressure plugs from (1) the inlet and (2) the intermediate pressure chamber.

There they place the connection nozzles of the system separator test device. You can find details in our "UWS L-BOXX PST" manual.

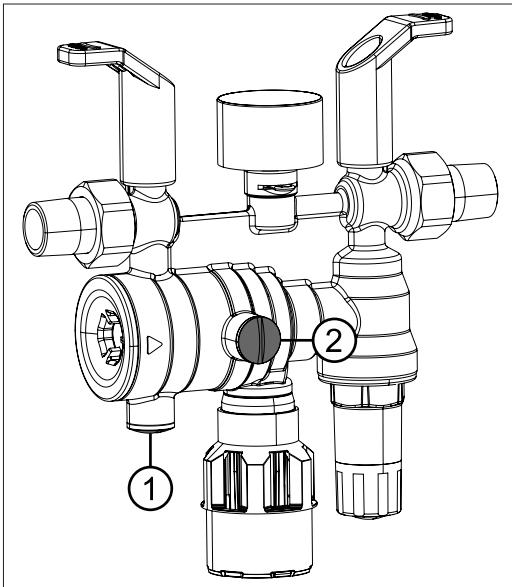

Changing the system separator cartridge

If the system separator cartridge is defective or dirty, it must be replaced or cleaned. The replacement set (system separator cartridge, assembly aid, assembly key, item no. 300930) can be ordered optionally.

❶ Close both barriers.

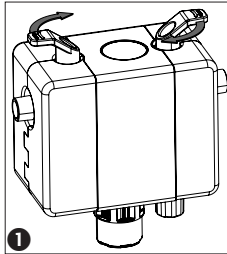

❷ Open the plug with the key.

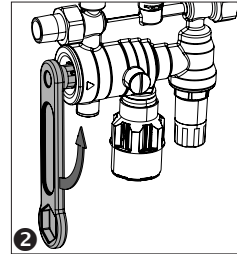

❸ Insert the assembly aid into the system separator cartridge and turn clockwise.

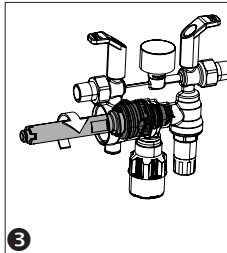

❹ Make sure that the two pins of the assembly wrench engage the tabs on the cartridge. Pull out the cartridge.

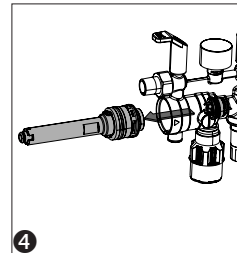

❺ Turn the assembly aid over and place it on the backflow preventer.

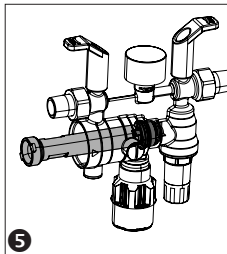

❻ Make sure that the recesses in the installation aid engage with the pins on the backflow preventer.

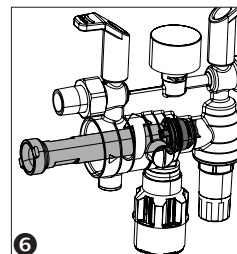

❼ Turn the assembly aid anti-clockwise and pull out the backflow preventer.

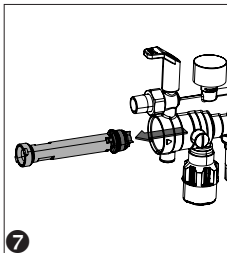

Installation is carried out in reverse order.

❽ Open the two barriers again.

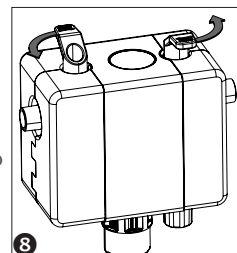

NOTE

Both maintenance and replacement must be documented.

Malfunctions - Troubleshooting

Defect	Caused	Remedy
The drain valve is open for no reason	Contamination of drain valve or backflow preventer (inlet side)	Remove the cartridge insert and clean or replace it. (*)
The drain valve does not close	Contamination of drain valve	Remove the cartridge insert and clean or replace it. (*)
The flow is low or non-existent	The refill combination was not installed in the flow direction	Mount the refill combination in the flow direction (see arrow directions)
	The barriers are not sufficiently opened	Open the barriers completely
	The pressure reducer is not set to the desired back pressure	Adjust the back pressure
Higher system pressure desired	The inlet pressure must be at least 1 bar higher than the desired system pressure.	Installation of a pressure booster.
	Please note that the last 0.5 bar before reaching the set value may take a longer time.	Wait until the pressure has automatically adjusted to the desired value.
fluctuations in the set back pressure	Contamination or damage to the nozzle or sealing disc on the valve insert.	Replace the valve insert (pressure reducer cartridge)
Water leaks from the adjustment handle	The membrane on the valve insert pressure reducer is defective	Replace the valve insert (pressure reducer cartridge)

*Cartridge inserts older than 1 year are not subject to complaint, as these are wearing parts and must be serviced annually according to DIN EN 1717 and DIN EN 806-5. (See UWS L-BOXX PST for easy testing of system separators type BA according to DIN EN 806-5, Art. No. 200001)

Technical data filling combination

	Filling combination BA
article number	300920
connections	R 1/2"
nominal width	DN 15
flow medium	potable water
Max. operating pressure	10 bar
Min. inlet pressure	2.5 bar for 1.5 bar heating system pressure
outlet pressure	1,5 - 6 bar
factory setting	1,5 bar
installation position	Horizontal with drain funnel downwards
Max. inlet temperature	30°C
Drain funnel connection	DN40
Filling capacity	1.5 m ³ /h at Δp 1.5 bar

Performance diagram filling combi 300920

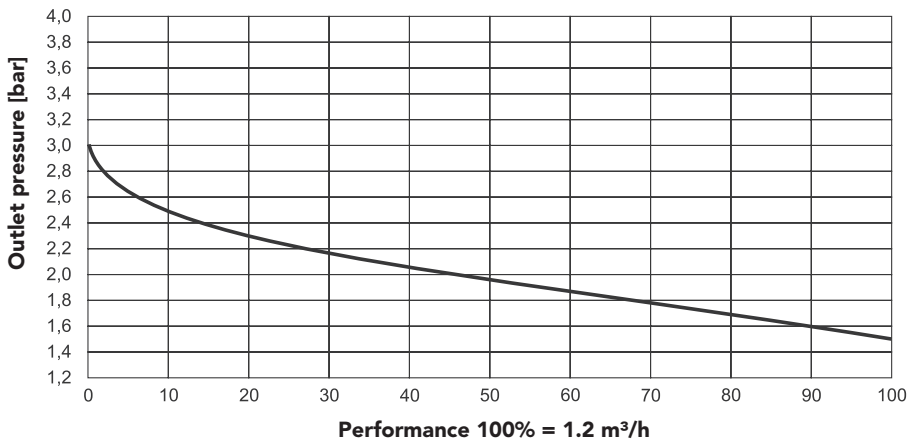

Filling combination dimensions

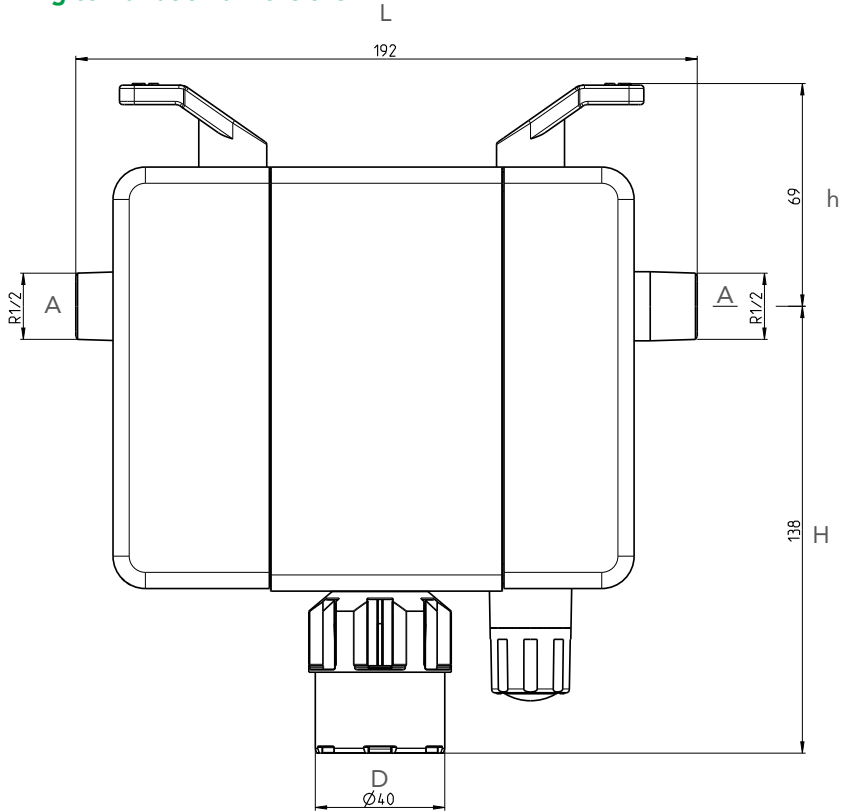

Type	Filling combination BA	
nominal width		DN 15
dimensions	A	R 1/2"
	H	138 (mm)
	h	69 (mm)
	L	192 (mm)
	D	40 (mm)

7 Spare parts

Spare parts Heaty Complete PROfessional

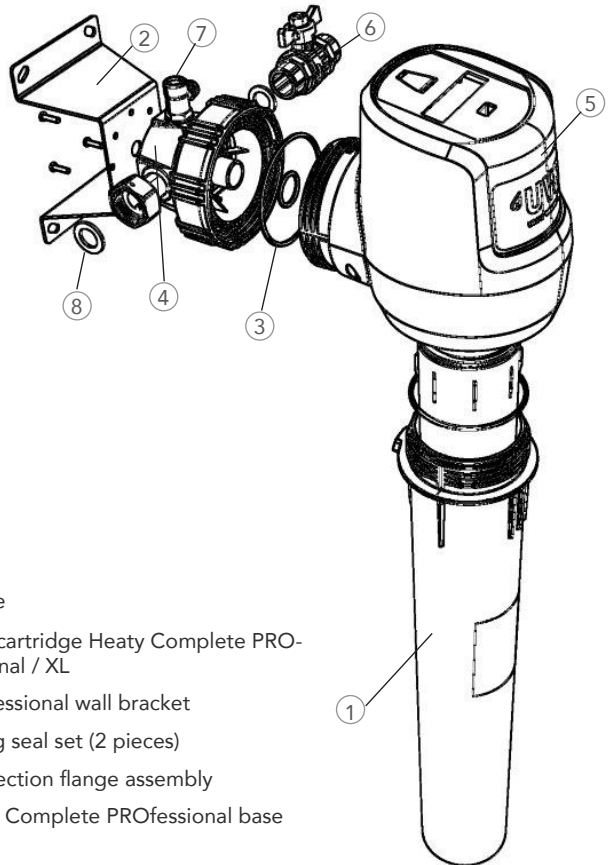

Art.-No.	Article
① 100854 / 100855	Refill cartridge Heaty Complete PROfessional / XL
② 120519	PROfessional wall bracket
③ 120520	O-ring seal set (2 pieces)
④ 120521	Connection flange assembly
⑤ 10392-1	Heaty Complete PROfessional base body
⑥ 120522	Ball valve brass 3/4" with seal
⑦ 120523	Drain valve 1/4"
⑧ 120524	Sealing set input_output
	Other spare parts
300920	Filling combination BA
100392-2	PROfessional power plug

**Spare parts
filling station wagon**

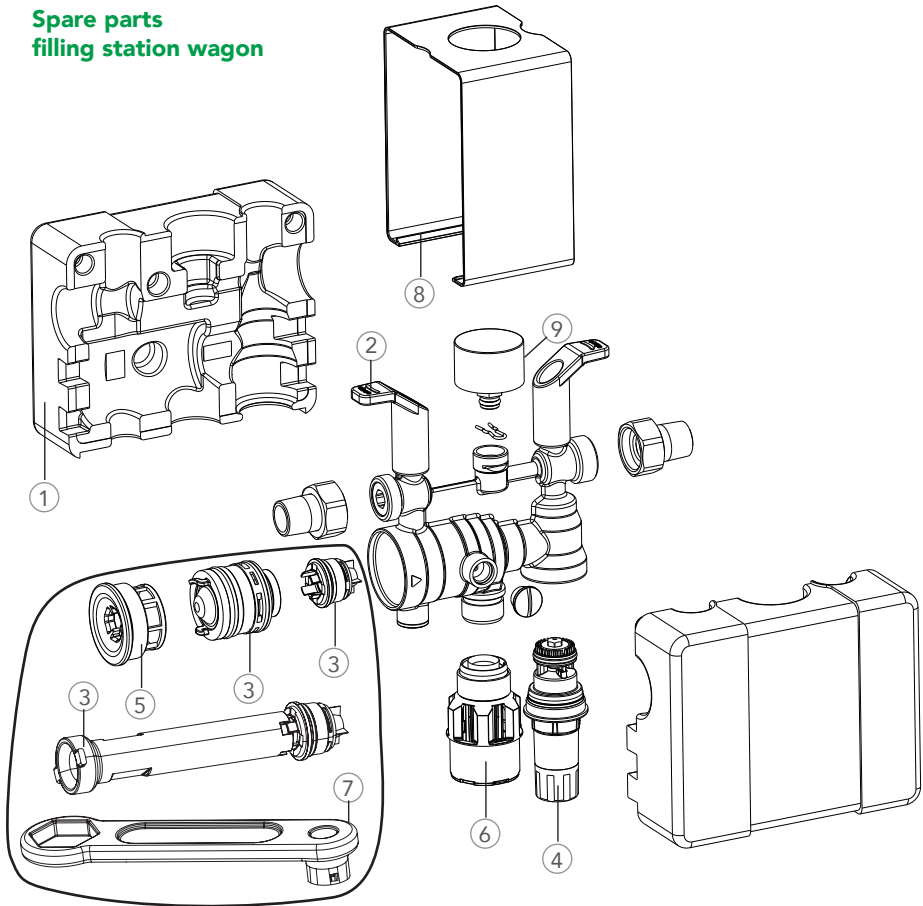

① Thermal insulation shell
300922

② Barrier handles
300923

④ Pressure reducer cartridge
300926

⑤ end cap
300927

⑥ Drain funnel
300928

⑦ Ring wrench
300929

⑧ Cover for thermal insulation shell
300924

⑨ Pressure gauge for 300920
300921

③ + ⑤ + ⑦ Mounting set for 300920
300930



EG-Konformitätserklärung



Hiermit erklären wir, dass das nachstehend bezeichnete Produkt in seiner Konzeption und Bauart sowie in der von uns in Verkehr gebrachten Ausführung den grundlegenden Sicherheitszielen der **EU-Richtlinie 2014/35/EU** entspricht. Bei einer mit uns nicht abgestimmten Änderung des Produkts verliert diese Erklärung ihre Gültigkeit.

Gegenstand der Erklärung:	Heaty Complete PROfessional
Seriennummer:	100392
Elektroanschluss:	230 V, 50 Hz
Betriebsdruck:	6 bar
Betriebstemperatur:	max 40 °C
Kapazität bei 420 µS/cm	122,5 l
Baujahr:	2024

Hersteller

UWS Technologie GmbH
Sudentenstraße 6
91610 Insingen

Konformität mit weiteren für das Produkt geltenden Richtlinien

- EU-Richtlinie zur elektromagnetischen Verträglichkeit (EMV) 2014/30/EU
- RoHS-Richtlinie 2011/65/EU
- Funkgeräte-Richtlinie 2014/53/EU

Angewandte harmonisierte Normen, insbesondere

- EN ISO 12100:2010: Sicherheit von Maschinen – allgemeine Gestaltungsleitsätze – Risikobeurteilung und Risikominderung
- EN 60204-1:2018: Sicherheit von Maschinen – Elektrische Ausrüstung von Maschinen – Teil 1: Allgemeine Anforderungen
- EN 60335-1:2012+AC:2014+ A11:2014+A13:2017 +A1:2019+A2:2019 +A14:2019: Sicherheit elektrischer Geräte für den Hausgebrauch und ähnliche Zwecke – Teil 1: Allgemeine Anforderungen
- EN IEC 61000-6-3: 2021: Elektromagnetische Verträglichkeit (EMV) – Teil 6-3: Fachgrundnormen – Störaussendung für Wohnbereich, Geschäfts- und Gewerbebereiche sowie Kleinbetriebe
- EN 61010-1: 2010 + A1:2019 + A1:2019/AC:2019: Sicherheitsbestimmungen für elektrische Mess-, Steuer-, Regel- und Laborgeräte – Teil 1: Allgemeine Anforderungen
- EN 61326-1:2021: Elektrische Mess-, Steuer-, Regel- und Laborgeräte – EMV-Anforderungen – Teil 1: Allgemeine Anforderungen

Bevollmächtigte Person für die Zusammenstellung der Technischen Dokumentation:

Mario Milkovic

Insingen, 11.11.2024

Ort / Datum

Thomas Schleep (Geschäftsführer)



EG-Konformitätserklärung



Hiermit erklären wir, dass das nachstehend bezeichnete Produkt in seiner Konzeption und Bauart sowie in der von uns in Verkehr gebrachten Ausführung den grundlegenden Sicherheitszielen der **EU-Richtlinie 2014/35/EU** entspricht. Bei einer mit uns nicht abgestimmten Änderung des Produkts verliert diese Erklärung ihre Gültigkeit.

Gegenstand der Erklärung:	Heaty Complete PROfessional XL
Seriennummer:	100393
Elektroanschluss:	230 V, 50 Hz
Betriebsdruck:	6 bar
Betriebstemperatur:	max 40 °C
Kapazität bei 420 µS/cm	225 l
Baujahr:	2024

Hersteller

UWS Technologie GmbH
Sudentenstraße 6
91610 Insingen

Konformität mit weiteren für das Produkt geltenden Richtlinien

- EU-Richtlinie zur elektromagnetischen Verträglichkeit (EMV) 2014/30/EU
- RoHS-Richtlinie 2011/65/EU
- Funkgeräte-Richtlinie 2014/53/EU

Angewandte harmonisierte Normen, insbesondere

- EN ISO 12100:2010: Sicherheit von Maschinen – allgemeine Gestaltungsleitsätze – Risikobeurteilung und Risikominderung
- EN 60204-1:2018: Sicherheit von Maschinen – Elektrische Ausrüstung von Maschinen – Teil 1: Allgemeine Anforderungen
- EN 60335-1:2012+AC:2014+ A11:2014+A13:2017 +A1:2019+A2:2019 +A14:2019: Sicherheit elektrischer Geräte für den Hausgebrauch und ähnliche Zwecke – Teil 1: Allgemeine Anforderungen
- EN IEC 61000-6-3: 2021: Elektromagnetische Verträglichkeit (EMV) – Teil 6-3: Fachgrundnormen – Störaussendung für Wohnbereich, Geschäfts- und Gewerbebereiche sowie Kleinbetriebe
- EN 61010-1: 2010 + A1:2019 + A1:2019/AC:2019: Sicherheitsbestimmungen für elektrische Mess-, Steuer-, Regel- und Laborgeräte – Teil 1: Allgemeine Anforderungen
- EN 61326-1:2021: Elektrische Mess-, Steuer-, Regel- und Laborgeräte – EMV-Anforderungen – Teil 1: Allgemeine Anforderungen

Bevollmächtigte Person für die Zusammenstellung der Technischen Dokumentation:

Mario Milkovic

Insingen, 11.11.2024

Ort / Datum

Thomas Schleep (Geschäftsführer)

Appendix 1

Menu complete

Heaty Complete PROfessional

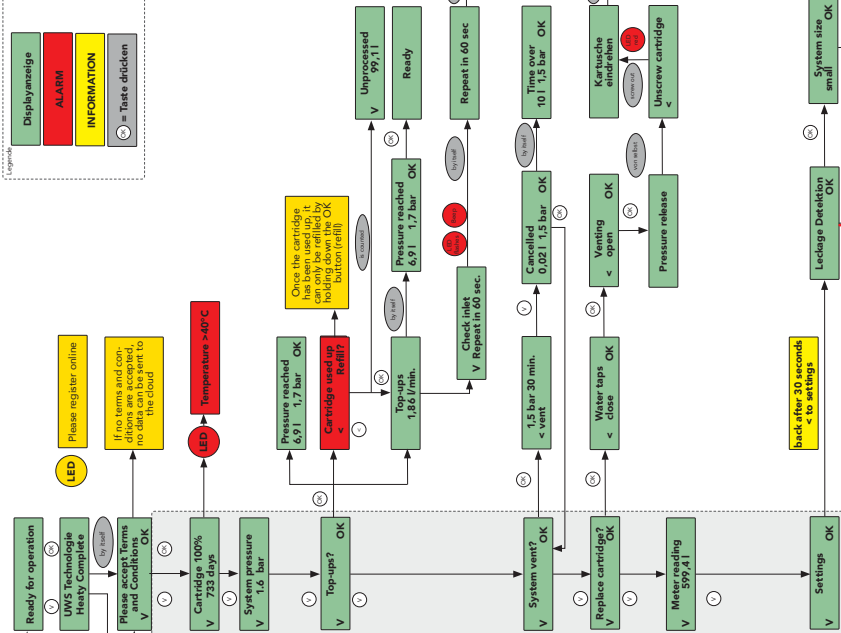
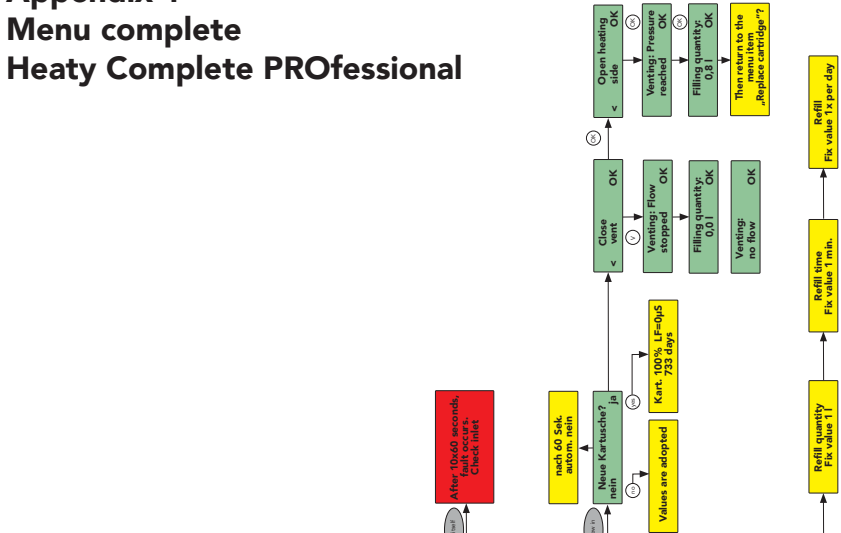
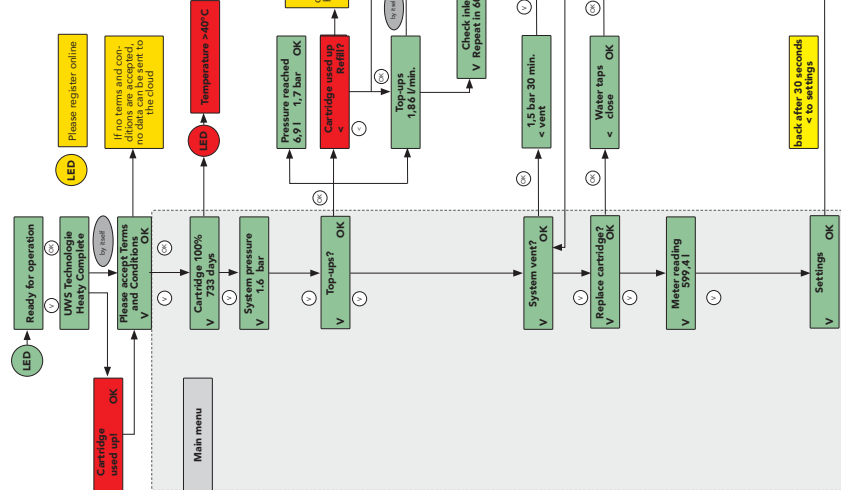
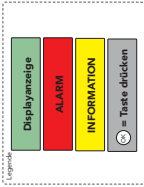

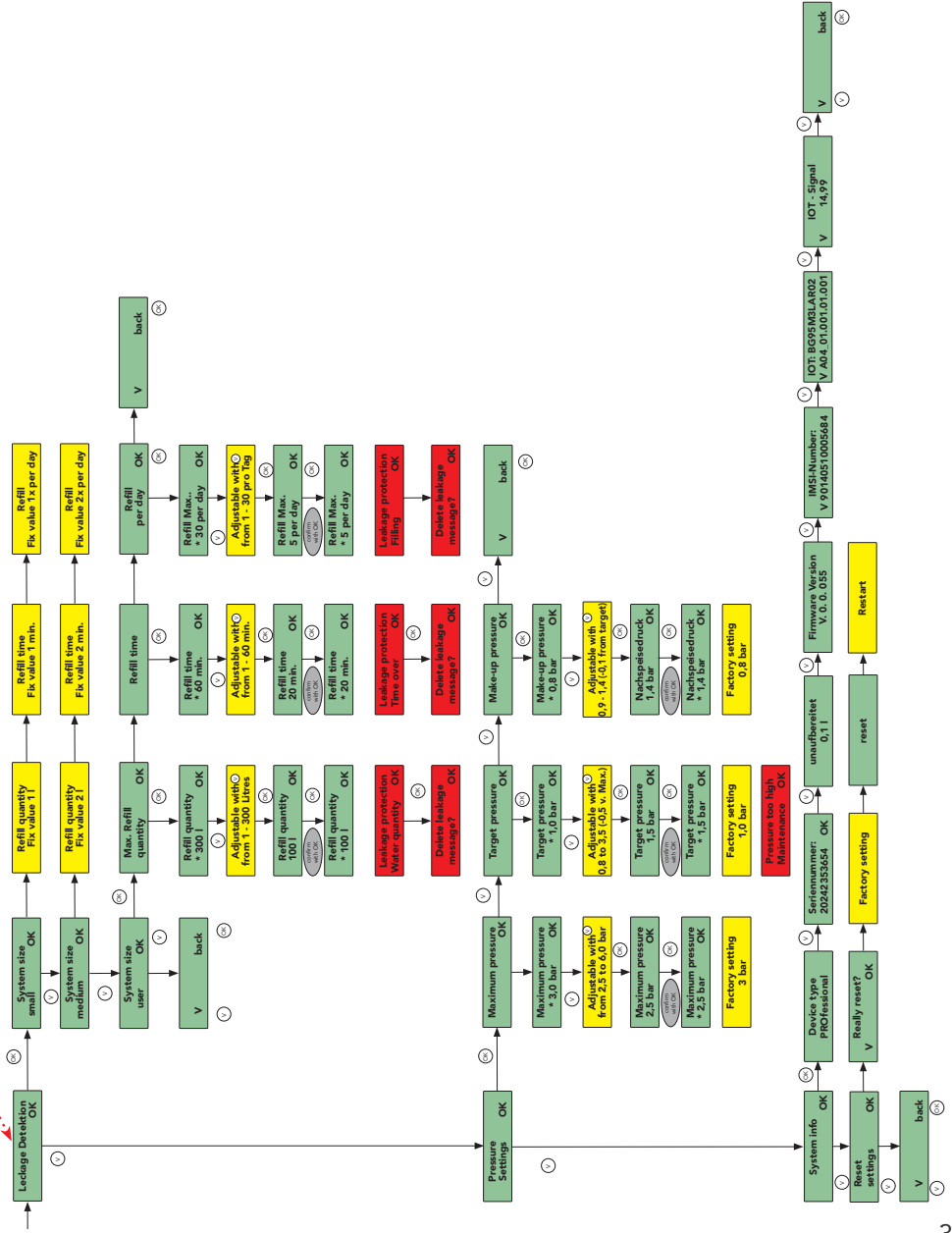

our water. safe.

YOUR CONTACT PERSON



Technical changes and innovations are reserved. Images may vary. UWS Technologie GmbH assumes no liability for the accuracy of technical information. Liability is excluded. Reproduction and distribution to third parties only with the express permission of UWS Technologie GmbH.

Status 11/2024

